

**LOCTITE®**

NORTH AMERICAN  
PRODUCT CATALOG

## LOCTITE® PRODUCT CATALOG

This is the first edition of the newly-redesigned LOCTITE® Product Catalog. With this edition, we've put an emphasis on the products you most frequently need, making it easier than ever to find the products that solve the majority of issues you will face for product design and assembly and for maintenance, repair and operation.

# Limitless Solutions to Help Unlock Your Limitless Potential.

LOCTITE® — The world's leading brand for adhesives, sealants and surface treatments — is obsessed with providing solutions that deliver products that are stronger, more durable, and long lasting. We help your designs and equipment operate and deliver on every task — from adhesives to lubricants that enhance your design capabilities and help maintain your equipment to function properly with the ability to repair them quickly and efficiently when needed. Limitless solutions unlocking your limitless potential.

275 to  
250 Mg

5

## Threadlockers

Prevent fastener loosening and seizure

15

## Thread Sealants

Prevent leaks – air, hydraulic

23

## Gasketing Products

Prevent flange leaks – oil, transmission, coolant

31

## Retaining Compounds

Prevent backlash – keyway wallowing, spun bearings, shaft misalignment, wear, corrosion

39

## Instant Adhesives

Bond dissimilar parts quickly and easily

49

## Universal Bonders

Bond a wide range of materials fast

57

## Structural Adhesives

Bond structural assemblies and repair damaged parts

69

## Flexible Adhesives and Sealants

Bond and seal parts that experience movement

77

## Light Cure Adhesives

On-demand curing

87

## Cleaners

Clean and degrease parts and work surfaces

93

## Wear Prevention

Fight rust, chemical corrosion and wear and improve performance.

101

## Rebuilding

Rebuild worn or corroded surfaces

109

## Lubricants

Prevent friction, heat or wear between metal surfaces

113

## Anti-Seize Products

Prevent rust, corrosion, galling or seizing on metal parts in extreme environments

119

## Specialty Maintenance Technologies

Solve nearly any issue with a wide range of solutions

125

## Nozzles

127

## Index



# OPTIMIZE ASSEMBLIES, REDUCE UNPLANNED DOWNTIME, WITH LOCTITE® SERVICES.

## HOW WE CAN HELP

LOCTITE® Services include line audits, plant surveys, inventory assessments, and in-person and online training to make your design, production and maintenance processes much more efficient.

## 01.

### DESIGN & ASSEMBLY

- Design guides
- Line surveys
- In-plant seminars
- Support through the developmental cycle

## 02.

### MAINTENANCE REPAIR & OVERHAUL

- Repair guides
- Plant surveys
- Maintenance Reliability Workshops
- Inventory consolidation

[services.loctite.com](https://services.loctite.com)





A LOCTITE® Territory Sales Engineer conducting a plant survey.



# THREAD LOCKERS

# Traditional fastening methods have gaps. Threadlockers fill them.



## PROBLEM

Without Threadlockers:  
Vibrational loosening  
due to 85% air gap.

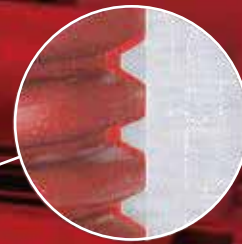

## SOLUTION

With Threadlockers:  
There's no vibrational  
loosening, and no gaps.

# Tighten your operation. Eliminate loosening.

Threadlockers lock and seal your threaded assemblies, protecting against vibration, corrosion and galling. But depending on your need, you have to choose the right Threadlocker and consider strength, form and removability. Which one will you need? LOCTITE® makes your choice easy.



## How to choose a threadlocker.



### STRENGTH & DISASSEMBLY

From heavy equipment and permanent assemblies to mounting bolts and adjustment screws, LOCTITE® has your Threadlocker.

#### LOW STRENGTH

Primarily used on adjustment screws, calibration screws, meters and gauges. They have high disassembly frequency and are removable with hand tools.

#### MEDIUM STRENGTH

Great for machine tools and presses, pumps and compressors, mounting bolts and gearboxes. They have normal disassembly frequency and are removable with hand tools.

#### HIGH STRENGTH

Used for more permanent assemblies, heavy equipment, suspension bolts, motor and pump mounts, cap bolts and studs. These are rarely disassembled and require localized heat for effective removal.



### FORM

Threadlockers come in a variety of different forms ranging from liquid, which flow smoothly into gaps and spaces, to semi-solid, a no-drip, no-mess formulation ideal for overhead applications. Knowing your application will help you select the correct Threadlocker.



### TEMPERATURE RESISTANCE

LOCTITE® Threadlockers are formulated to withstand extreme temperatures for continuous service from application to removal.



BEST SELLER

## 243™ Blue Threadlocker

General Purpose, Medium Strength

Works on all metals, including passive substrates such as stainless steel, aluminum and plated surfaces. Proven to be tolerant of minor contamination due to industrial oils, e.g. motor oils, corrosion prevention oils and cutting fluids.



Disassembly: Removable with hand tools



Form: Liquid



Temperature Resistance: 360°F



BEST SELLER

## 263™ Red Threadlocker

General Purpose, High Strength

Works on all metals, including passive substrates such as stainless steel, aluminum and plated surfaces. Proven to be tolerant of minor contamination due to industrial oils, e.g. motor oils, corrosion prevention oils and cutting fluids. For parts not expected to be disassembled.



Disassembly: Localized heat required for removal



Form: Liquid



Temperature Resistance: 360°F



# Find the right product for your application



## DISASSEMBLY

### Medium Strength

- LOCTITE <sup>®</sup> **243**<sup>™</sup>
- LOCTITE <sup>®</sup> **248**<sup>™</sup>
- LOCTITE <sup>®</sup> **290**<sup>™</sup>

### Low Strength

- LOCTITE <sup>®</sup> **222MS**<sup>™</sup>

### High Strength

- LOCTITE <sup>®</sup> **263**<sup>™</sup>
- LOCTITE <sup>®</sup> **268**<sup>™</sup>
- LOCTITE <sup>®</sup> **277**<sup>™</sup>

## Medium Strength

### THREADLOCKERS



**243**<sup>™</sup>  
General Purpose



Disassembly: Removable with hand tools



Form: Liquid



Temperature Resistance: 360°F

Viscosity: 2,150 cP Thixotropic  
Breakaway Torque: 230/40 in.- lbs.  
Fixture Speed: 10 minutes  
Full Cure: 24 hours



**248**<sup>™</sup>  
No-drip, No-mess



Disassembly: Removable with hand tools



Form: Semi-solid



Temperature Resistance: 300°F

Viscosity: Semi-solid  
Breakloose Torque: 225 in.-lbs.  
Fixture Speed: 5 minutes  
Full Cure: 24 hours



**290**<sup>™</sup>  
Wicking Grade



Disassembly: Removable with hand tools



Form: Liquid



Temperature Resistance: 300°F

Viscosity: 40 cP  
Breakaway Torque: 90/260 in.- lbs.  
Fixture Speed: 20 minutes  
Full Cure: 24 hours

## Low Strength

### THREADLOCKERS



**222MS**<sup>™</sup>  
General Purpose



Disassembly: Removable with hand tools



Form: Liquid



Temperature Resistance: 300°F

Military Spec: Mil-S-46163A  
Viscosity: 1,200 cP Thixotropic  
Breakaway Torque: 53/30 in.- lbs.  
Fixture Speed: 20 minutes  
Full Cure: 24 hours

# High Strength

## THREADLOCKERS



**263™**  
General Purpose



Disassembly: Localized heat required for removal



Form: Liquid



Temperature Resistance: 360°F

Viscosity: 500 cP  
Breakaway Torque: 290/290 in.- lbs.  
Fixture Speed: 10 minutes  
Full Cure: 24 hours



**268™**  
No-drip, No-mess



Disassembly: Localized heat required for removal



Form: Semi-solid



Temperature Resistance: 300°F

Viscosity: Semi-solid  
Breakaway Torque: 355 in.-lbs.  
Fixture Speed: 5 minutes  
Full Cure: 24 hours



**277™**  
Large Bolts



Disassembly: Localized heat required for removal



Form: Liquid



Temperature Resistance: 300°F

Viscosity: 7,000 cP Thixotropic  
Breakaway Torque: 280/280 in.- lbs.  
Fixture Speed: 45 minutes  
Full Cure: 24 hours

LOCTITE SERVICES

# STOP FASTENER FAILURE BEFORE IT HAPPENS.

[services.loctite.us](https://services.loctite.us)

## Surface Preparation

THREADLOCKERS



**SF 7070**™  
Cleaner  
IDH 231562

A general purpose parts cleaner formulated for metals and plastics. The product is able to remove most oils, greases, lubrication fluids, metal cuttings and dries residue free.



**SF 7649**™  
Primer  
IDH 209715

Designed to promote the curing speed of LOCTITE anaerobic adhesives and sealants without any significant loss of joint strength. Especially recommended for applications with passive metals or inert surfaces and with large bond gaps.

## Equipment

THREADLOCKERS



### NEW LOCTITE® Pro Pump Handheld Dispenser

IDH 2564842

Our all-new easy to use, light-weight, durable applicator that allows for precision application of Threadlockers, retaining compounds and thread sealants.



### LOCTITE® Dual Channel Integrated Reservoir

IDH 1390321/ 1390322

This dispenser combines a dual channel dispense controller and reservoir. It provides two timing channels controlling two pneumatic outputs, such as dispense valves, advancing slides, or any other pneumatic device. Well suited for medium to high viscosity (> 3,000 cP) adhesives.

### ADDITIONAL EQUIPMENT

#### Bond-A-Matic® 3000 Dispenser

IDH 209685/218323

#### Pneumatic Handheld Applicator

IDH 88643

#### Stationary Applicator Valve

IDH 88644/88645

## New LOCTITE® Pro Pump Handheld Dispenser for easy application.

For a full lineup of equipment to support your needs visit [equipment.loctite.com](http://equipment.loctite.com)



## THREADLOCKERS

Product	IDH Number	Pack Size	Color	Features	Viscosity (cP) 20 RPM	Thixotropic (yes/no)	Breakaway Torque/ Prevail Torque, M10 Steel Nuts and Bolts (N/m, in.- lbs.)	Temperature Range	Fixture Time (min)
<b>LOW STRENGTH</b>									
<b>222MS™</b>	135333	10 ml	Purple	Small screw, general purpose	1,200	Yes	6/4 N/m, 53/30 in.- lbs.	-65°F to 300°F (-55°C to 150°C)	20
	135334	50 ml							
<b>MEDIUM STRENGTH</b>									
<b>243™</b>	1329467	50 ml	Blue	General Purpose Primerless	2,150	Yes	26/5 N/m, 230/40 in.- lbs.	-65°F to 360°F (-55°C to 180°C)	10
	1329505	250 ml							
<b>248™</b>	826034	9 g	Blue	Easy application semisolid stick	Semi-solid	-	23/200 N/m	-65°F to 300°F (-55°C to 150°C)	5
	462476	19 g							
<b>290™</b>	135392	50 ml	Green	Post application wicking capability	40	No	10/29 N/m, 90/260 in.- lbs.	-65°F to 300°F (-55°C to 150°C)	20
	135393	250 ml							
<b>HIGH STRENGTH</b>									
<b>263™</b>	1330585	50 ml	Red	General Purpose	500	No	33/33 N/m, 290/290 in.- lbs.	-65°F to 360°F (-55°C to 180°C)	10
	1330335	250 ml							
<b>268™</b>	826036	9 g	Red	Easy application semisolid stick	Semi-solid	-	10/90 N/m	-65°F to 300°F (-55°C to 150°C)	5
	826035	19 g							
<b>277™</b>	88448	50 ml	Red	Ideal for large bolts with coarse threads	7,000	Yes	32/32 N/m, 280/280 in.- lbs.	-65°F to 300°F (-55°C to 150°C)	45
	88449	250 ml							

SEE THE FULL LINE OF THREADLOCKERS AT:  
[threadlockers.loctite.us](http://threadlockers.loctite.us)



# Keeping a Wind Generator Operating Safely



“Thanks to our LOCTITE Engineering Solutions Expert, we don’t have to worry about corrosion or catastrophic fastener failure.”

A wind farm erecting its first wind generator wanted to insure that the bolts attaching the blade to the hub maintained the designed torque and were protected from the corrosion that can occur with exposure to the elements. The ideal solution was LOCTITE® 243™ Threadlocker, which helps prevent catastrophic failure by resisting vibrational loosening, preventing thread corrosion and maintaining fastener torque in the wing to hub assembly. A LOCTITE Engineering Solutions Expert helped the team remove the protective shipping covers from the exposed bolt

threads and clean the steel fasteners. They then inserted the blade into the main hub applied LOCTITE® 243™ Threadlocker to the fasteners, torqued the blade to hub assembly to specification and mounted the hub to the generator drive system. Now, with corrosion free fasteners that maintain clamp load, and that are easily disassembled at a predictable break loose torque, the wind farm is assured of safe, maintenance-free wind turbine operation until scheduled downtime.

## BENEFITS

LOCTITE® 243™ Threadlocker:

- Fills the gaps between threads to prevent movement between the nut and bolt
- Eliminates vibrational loosening, maintaining the original fastener torque and insuring safe operation
- Prevents corrosion that makes disassembly difficult



# THREAD SEALANTS

# Leaks cause downtime. Liquid thread sealants prevent them.

---



## PROBLEM

With conventional thread sealants: Pressurized fluids and gas can cause costly leaks and downtime.

## SOLUTION

With liquid thread sealants: Joints are sealed to the burst point of most piping systems.

# Seal out leaks. Seal in productivity.

Thread sealants fill the space between threaded parts and provide an instant, low pressure seal that prevents fluid and gas leaks which can cause costly downtime. LOCTITE has a variety of thread sealants, and the one you need will depend on your system material and thread type.

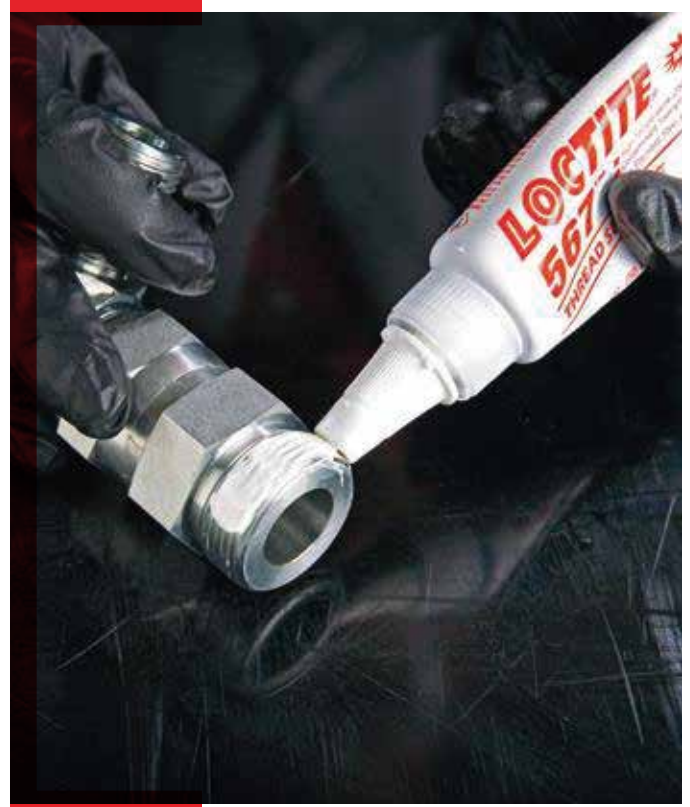

## How to choose a thread sealant.



### SUBSTRATE

There's a LOCTITE thread sealant for any type of piping system.

#### METAL

For metal-to-metal pipe connections and fittings, use LOCTITE anaerobic thread sealants. They cure in the absence of air and by contact with metals.

#### PLASTIC

Ideal for use on threaded plastic or plastic/metal substrate combinations.



### THREAD TYPE

There are two types of threads to consider. The National Pipe Taper (NPT) seal, most widely used in the United States and Canada, which requires a lower strength thread sealant for disassembly. The British Standard Pipe Taper (BSPT), more common in other countries, requires a higher strength thread sealant in order to seal the connection properly.



### FORM

Thread sealants are available in a variety of forms, from liquid to paste to solid. Each is suited to different applications. Liquids are ideal for flowing into gaps in threaded connections. Pastes and solids are best for overhead applications where it's necessary to prevent drips, or an instant seal is needed.



BEST SELLER

## 567™

General Purpose Paste

LOCTITE 567™ is a general purpose thread sealant which provides an instant seal. Tolerates minor surface contaminants, rated up to 400°F operating temperature.



Substrate: Metal



Thread Type: Tapered, NPT and Straight



Form: Anaerobic Paste



BEST SELLER

## 545™

Hydraulic and Pneumatic Fittings

LOCTITE 545™ is a pipe thread sealant designed for locking and sealing of metal pipes and fittings. It is specially formulated to offer high lubricity for easy assembly and removal. Recommended for fine threaded fittings as used in hydraulic and pneumatic installations and small fittings in general.



Substrate: Metal



Thread Type: Fine



Form: Liquid Anaerobic



Find the right product for your application



 SUBSTRATE

Metal

- LOCTITE <sup>®</sup> **567**<sup>™</sup>
- LOCTITE <sup>®</sup> **545**<sup>™</sup>
- LOCTITE <sup>®</sup> **561**<sup>™</sup>
- LOCTITE <sup>®</sup> **5452**<sup>™</sup>

Plastic

- LOCTITE <sup>®</sup> **MR 5438**<sup>™</sup>

**Metal** THREAD SEALANTS



**567**<sup>™</sup>  
General Purpose



Substrate: Metal



Thread Type: Tapered, NPT and Straight



Form: Paste

Viscosity: 540,000 Thixotropic  
Temperature Resistance: 400°F



**545**<sup>™</sup>  
Hydraulic and Pneumatic Fittings



Substrate: Metal



Thread Type: Fine



Form: Liquid

Viscosity: 15,000 cP  
Temperature Resistance: 300°F



**561**<sup>™</sup>  
No-drip, No-mess



Substrate: Metal



Thread Type: Tapered and Straight



Form: Semi-solid

Viscosity: Semi-solid  
Temperature Resistance: 300°F



**5452**<sup>™</sup>  
Hydraulic/Pneumatic, Fast Cure



Substrate: Metal



Thread Type: Coarse and Fine



Form: Gel

Viscosity: 28,000 Thixotropic  
Temperature Resistance: 360°F

**Plastic** THREAD SEALANTS



**MR 5438**<sup>™</sup>  
General Purpose



Substrate: Plastic



Thread Type: Tapered and Straight



Form: Paste

Viscosity: 100,000 cP  
Temperature Resistance: 300°F

SEE OUR FULL LINE OF  
THREAD SEALANTS:  
[thread-sealants.loctite.us](http://thread-sealants.loctite.us)

## Surface Preparation

### THREAD SEALANTS



**SF 7070™**  
Cleaner  
IDH 231562

A general purpose parts cleaner formulated for metals and plastics. The product is able to remove most oils, greases, lubrication fluids, metal cuttings and dries residue free.



**SF 7649™**  
Primer  
IDH 209715

Designed to promote the curing speed of LOCTITE anaerobic adhesives and sealants without any significant loss of joint strength. Especially recommended for applications with passive metals or inert surfaces and with large bond gaps.

## Equipment

### THREAD SEALANTS



**Dial-A-Seal®**  
IDH 998400

The Dial-A-Seal Applicator is a touch-actuated, all pneumatic applicator for dispensing high viscosity LOCTITE product onto threaded pipe fittings and nipples.



**NEW LOCTITE® Pro Pump Handheld Dispenser**  
IDH 2564842

Our all-new easy to use, light-weight, durable applicator that allows for precision application of threadlockers, retaining compounds and thread sealants in 50/250 ml bottles.

### ADDITIONAL EQUIPMENT

#### 50 ml F Tube Squeeze Dispenser

IDH 1083845

### THREAD SEALANTS

Product	IDH Number	Pack Size	Features	Color	Viscosity mPa-s, 20 RPM [cP]	Thixotropic (yes/no)	Temperature Range	Breakaway Torque Steel M10 [N/m]
<b>METAL</b>								
<b>567™</b>	2087067	50 ml	For Stainless Steel, high temperature	White	540,000*	Yes	-65°F to 400°F (-55°C to 200°C)	12
	2087069	250 ml						
<b>545™</b>	135486	50 ml	Pneumatic hydraulic sealant, no fillers	Purple	15,000*	No	-65°F to 300°F (-55°C to 150°C)	2
<b>561™</b>	463973	19 g	Easy application, general purpose	White	Semi-solid	-	-65F to 300F (-55°C to 150°C)	6
<b>5452™</b>	1265769	50 ml	Pneumatic hydraulic sealant, no fillers, High Viscosity, Fast Cure	Purple	28,000	Yes	-65°F to 360°F (-55°C to 180°C)	3.5
	1265770	250 ml						
<b>PLASTIC</b>								
<b>MR 5438™</b>	1537780	16 oz	Plastic pipes, easy disassembly, alcohol base and non-hardening	White	100,000	No	-65°F to 300°F (-55°C to 150°C)	NA

\*20 RPM

\*\*M10 Black Oxide

\*\*3/8 x16 Zinc Phosphate

### LOCTITE SERVICES

PREVENT COSTLY LEAKS AND UNPLANNED DOWNTIME.

services.loctite.us



# Putting a Stop to Leaking Fittings



“LOCTITE helped us reduce downtime and labor costs with a better, longer-lasting solution.”

A compressor service company serving the natural gas production, processing, and transportation industry faced an increasing number of leaks on NPT fittings. Pipe dopes and PTFE tapes lacked sufficient sealing properties, and tapes might loosen and leak during equipment operation. And both options still meant downtime and high labor costs to rework fittings. A product is needed that seals NPT fittings and prevents thread galling during assembly. LOCTITE® 567 PST™ Thread Sealant, which prevents thread galling and has high locking strength to prevent leaks, was an ideal alternative.

The LOCTITE Engineering Solutions Expert showed the team how to clean the fittings, apply LOCTITE® 567 PST™ to the leading threads, and properly tighten. Immediately, the fittings were sealed up to 1000 psi, and the company’s large natural gas compressors will run leak-free until the system is disassembled for required maintenance, lowering operating costs.

## BENEFITS

LOCTITE® 567 PST™ Thread Sealant:

- Provides lubrication to prevent thread galling on NPT fittings
- Has sufficient locking strength to maintain a complete seal during transport and operation
- Has significantly lowered rework costs associated with equipment fitting leaks



# GASKETING PRODUCTS

# Cut gaskets leak. We seal.

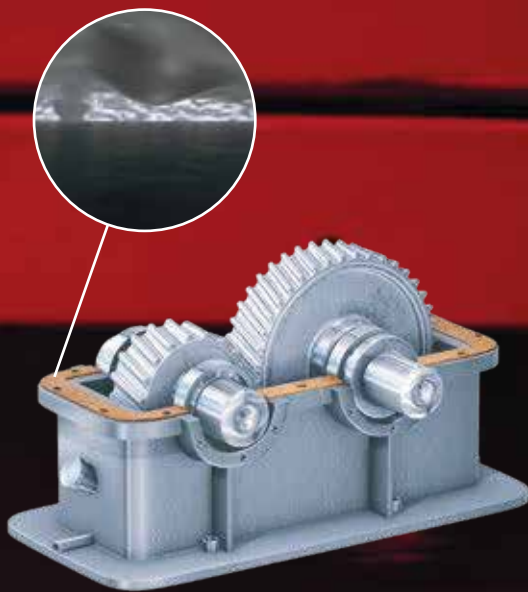

## PROBLEM

With compression gaskets:  
Not all surface imperfections are filled.  
They distort, relax under compression  
and displace from the joint.

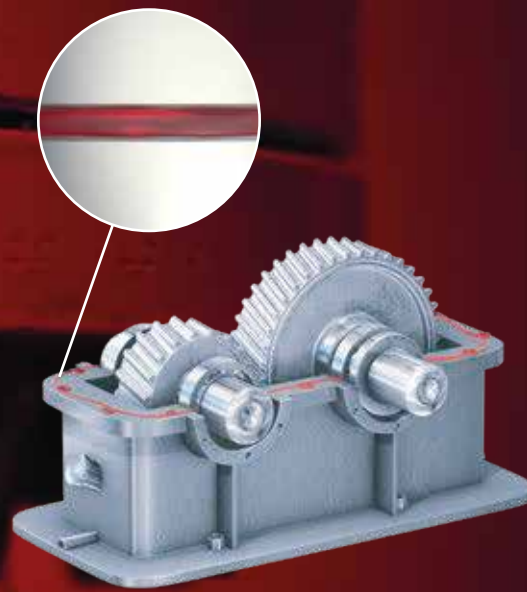

## SOLUTION

With liquid gaskets:  
When assembled, all surface imperfections  
are filled, adding structural stiffness and  
eliminating micromovement and slipping.  
They do not shrink, crack or suffer from  
relaxation.

# Liquid gaskets hold up better. For longer lasting seals.

To provide a leak-free seal over a long period of time, gaskets must fill voids and be resistant to liquids and/or gases, while withstanding the operating temperatures and pressures to which they are subjected. LOCTITE offers a range of gasketing products designed for any flange type, gap size or material.



## How to choose a gasketing product.



### FLANGE TYPE

#### RIGID MACHINED FLANGES

Rigid, machined flange surfaces typically are designed for no gap, allowing for metal to metal contact. For these assemblies anaerobic liquid gaskets are the best choice because they provide the highest strength seal.

#### STAMPED OR FLEXIBLE FLANGES

Typically thinner, stamped metal flanges can have larger gaps that need to be filled. They are also subject to more flex in service. For these types of assemblies, silicone liquid gasketing products provide the best seal.



BEST SELLER

## 518™ Pen

No-drip, No-mess

The new LOCTITE 518™ Pen is a leak-fighting flange sealant with an easy to apply roll-on applicator. It's the fastest way to apply reliable and long-lasting liquid gaskets, without any mess or waste. Rigid, machined flange surfaces typically are designed for no gap, allowing for metal to metal contact. For these assemblies anaerobic liquid gaskets are the best choice because they provide the highest strength seal.



Flange Type: Rigid Machined Flange



BEST SELLER

## SI 5910™

High Adhesion

LOCTITE SI 5910™ is a low strength, silicone-based gasketing product designed for use on flexible flanges with machined or cast surfaces. It has good resistance against oil and joint movement. Typical applications include stamped sheet metal covers. Typically thinner, stamped metal flanges can have larger gaps that need to be filled. They are also subject to more flex in service. For these types of assemblies, silicone liquid gasketing products provide the best seal.



Flange Type: Stamped/Flexible Flange



Find the right product for your application



 FLANGE TYPE

Rigid Machined Flange

- LOCTITE <sup>®</sup> **518**<sup>™</sup>
- LOCTITE <sup>®</sup> **518**<sup>™</sup> Pen
- LOCTITE <sup>®</sup> **510**<sup>™</sup>
- LOCTITE <sup>®</sup> **NS 5540**<sup>™</sup>
- LOCTITE <sup>®</sup> **NS 5550**<sup>™</sup>

Stamped Flange

- LOCTITE <sup>®</sup> **SI 5699**<sup>™</sup>
- LOCTITE <sup>®</sup> **SI 5910**<sup>™</sup>
- LOCTITE <sup>®</sup> **SI 5900**<sup>™</sup>
- LOCTITE <sup>®</sup> **SI 596**<sup>™</sup>

Rigid Machined Flange

GASKETING PRODUCTS



**518**<sup>™</sup>  
General Purpose

Color: Red  
Viscosity: 750,000 cP Thixotropic  
Temperature Resistance: 300°F  
Cure Method: Anaerobic



**518**<sup>™</sup> Pen  
No-drip, No-mess

Color: Red  
Viscosity: 750,000 cP Thixotropic  
Temperature Resistance: 300°F  
Cure Method: Anaerobic



**510**<sup>™</sup>  
High Temperature

Color: Opaque Pink  
Viscosity: 90,000 cP Thixotropic  
Temperature Resistance: 400°F  
Cure Method: Anaerobic



**NS 5540**<sup>™</sup>  
Extreme Temperature

Color: Brown  
Viscosity: 48,000 cP  
Temperature Resistance: 1,300°F  
Cure Method: Heat



**NS 5550**<sup>™</sup>  
Extreme Temperature

Color: Brown  
Viscosity: 2,000,000 cP  
Temperature Resistance: 1,500°F  
Cure Method: Heat

Stamped Flange

GASKETING PRODUCTS



**SI 5699**<sup>™</sup>  
Chemical Resistant

Color: Grey  
Viscosity: Paste  
Temperature Resistance: 392°F  
Cure Method: Moisture



**SI 5900**<sup>™</sup>  
Instant Seal

Color: Black  
Viscosity: Paste  
Temperature Resistance: 392°F  
Cure Method: Moisture



**SI 5910**<sup>™</sup>  
High Adhesion

Color: Black  
Viscosity: Paste  
Temperature Resistance: 392°F  
Cure Method: Moisture



**SI 596**<sup>™</sup>  
High Temperature

Color: Red  
Viscosity: Paste  
Temperature Resistance: 600°F  
Cure Method: Moisture

SEE OUR FULL LINE OF  
GASKETING PRODUCTS:  
[gaskets.loctite.us](http://gaskets.loctite.us)

# Surface Preparation

## GASKETING PRODUCTS



**SF 790™**  
Part Cleaner  
IDH 135544

A gray to off-white methylene chloride liquid solvent in an aerosol spray designed to remove baked-on chemical gaskets, gasket cements and conventional gasket materials from metal surfaces. Its aerosol spray form enables spray application on to intricate shapes with maximum penetration.



**SF 7649™**  
Primer  
IDH 209715

Designed to promote the curing speed of LOCTITE® anaerobic adhesives and sealants without any significant loss of joint strength. Especially recommended for applications with passive metals or inert surfaces and with large bond gaps.

# Equipment

## GASKETING PRODUCTS



**HD10 Pneumatic Handheld 300 ml Cartridge Dispenser**

IDH 1714379

A manually controlled applicator that dispenses product from 300 ml cartridges or 250 ml tubes (when tube adapter 989347 is used). The cartridge or tube is pneumatically pressurized and product is dispensed from the nozzle while the trigger is depressed.



**Manual Cartridge Applicator**

IDH 1093940

A hand-held, manually operated meter-mix dispenser. These dispensers provide a convenient, cost-effective method to apply product with minimal waste. The dispensers are compatible with 1:1 and 1:2 mix ratio products.

GASKETING PRODUCTS									
Product	IDH Number	Pack Size	Color	Features	Max Gap Fill Unprimed	Viscosity [cP] 20 RPM	Thixotropic (yes/no)	Temperature Range	Fixture Time [min] Steel
<b>RIGID MACHINED FLANGES</b>									
<b>518™</b>	2096061	50 ml	Red	Ideal for use on rigid iron, steel and aluminium flanges	0.01 in. (0.25 mm)	750,000	Yes	-65°F to 300°F (-55°C to 150°C)	25
	2096064	300 ml							
<b>518™ Pen</b>	2392164	25 ml	Red	Roll on applicator	0.005 in (0.125 mm)	750,000	Yes	-65°F to 300°F (-55°C to 150°C)	25
<b>510™</b>	135474	50 ml	Opaque Pink	High Temperature Applications	0.01 in. (0.25 mm)	90,000**	Yes	-65°F to 400°F (-55°C to 200°C)	25
	234225	250 ml							
<b>NS 5540™</b>	2374452	1 pint	Brown	High Temperature	0.005 in (0.125 mm)	48,000	No	-40°F to 1300°F (-40°C to 704°C)	Heat cure product
<b>NS 5550™</b>	2374447	1 quart	Brown	High Temperature	0.025 in. (0.64 mm)	2,000,000	No	-40°F to 1500°F (-40°C to 815°C)	Heat cure product

Product	IDH Number	Pack Size	Color	Feature	Viscosity* cPs (Mpas) or Extrusion Rate** g/min	Temperature Range	Tack Free Time (min)
<b>STAMPED OR FLEXIBLE FLANGES</b>							
<b>SI 596™</b>	135507	80 ml	Red	High temperature (acetic acid silicone)	73,000 cPs*	-75°F to 600°F (-59°C to 316°C)	30
	198817	300 ml					
<b>SI 5699™</b>	135275	70 ml	Grey	For flexible flanges, machined or cast surfaces, metal or plastic, increased oil resistance	200 g/min**	-67°F to 392°F (-55°C to 200°C)	30
	135270	300 ml					
<b>SI 5900™</b>	743912	90 ml	Black	Excellent oil resistance, high adhesion, high joint movement, excellent in water/glycol	30 g/min**	-67°F to 392°F (-55°C to 200°C)	15
	743913	190 ml					
<b>SI 5910™</b>	231232	300 ml	Black	High joint movement, oil resistance, good on wide variety of plastics, glasses, ceramic, metals	500 g/min**	-67°F to 392°F (-55°C to 200°C)	40

\*Note: To increase gap fill, use a primer  
\*\*Different viscosity test used

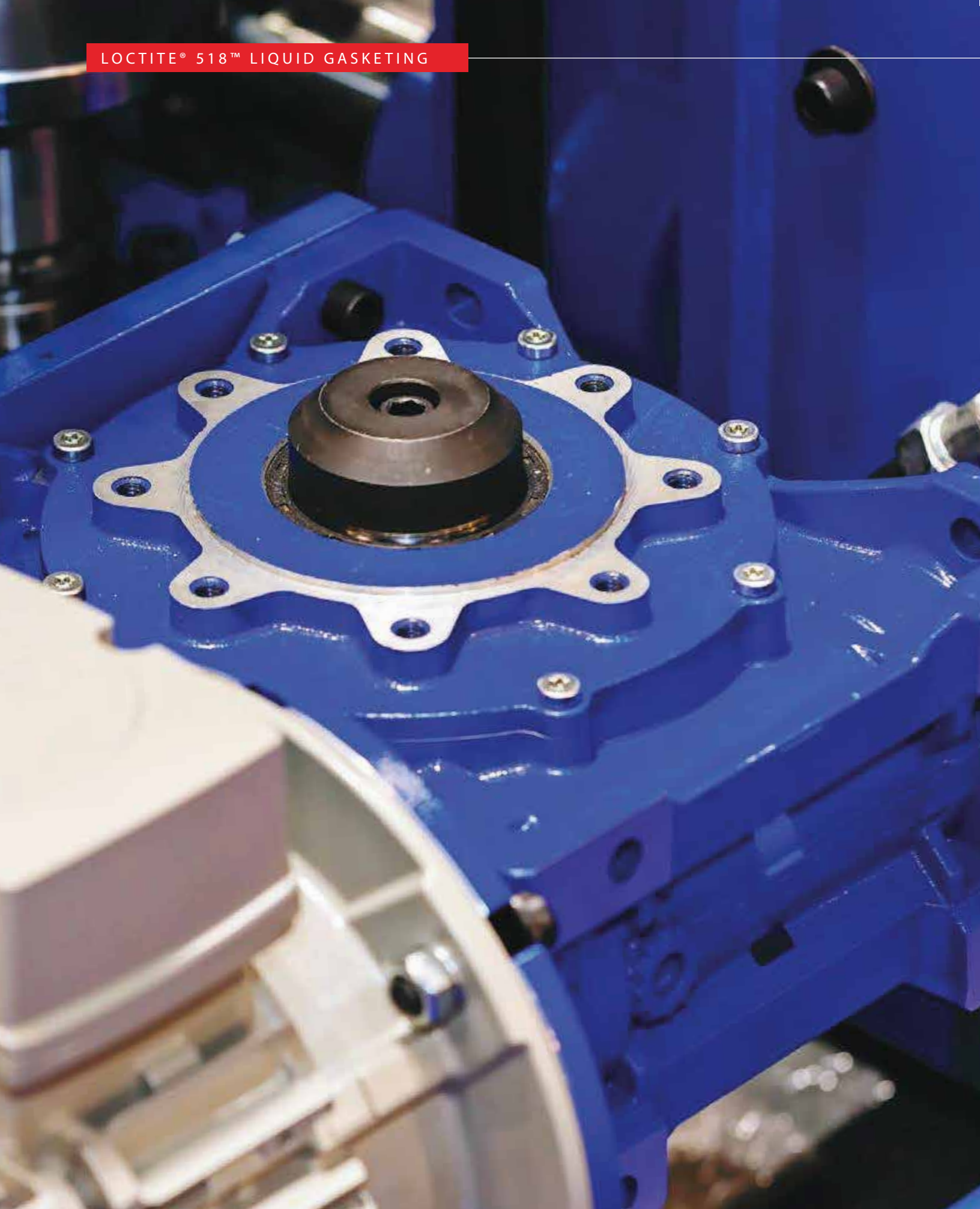

# A Costly 5% Leakage Rate Eliminated



“A high leakage rate was causing warranty claims and production delays. LOCTITE’s Engineering Solutions Expert helped us completely eliminate the problem.”

A manufacturer of cast iron gear boxes and geared motors experienced a 5% leakage rate using a competitor’s liquid gasket on the adapter assembly flange. This was costly due to both leakage-related warranty claims on purchased units and testing and production delays caused by the slow cure rate. The competitive product also made it difficult to disassemble and repair the gearbox. LOCTITE® 518™ Gasket Sealant was an ideal solution, offering a complete seal, quick

curing, and easy disassembly. A LOCTITE® Engineering Solutions Expert showed the plant’s team how to clean flange surfaces and dispense LOCTITE® 518™ in a continuous bead. Immediately following assembly LOCTITE® 518™ fills the gaps between the flange surfaces and the products can be instantly pressure tested to 40 psi. Leaks have now been eliminated and disassembly is easier for customers.

## BENEFITS

LOCTITE® 518™ Gasket Sealant :

- Seals more effectively, eliminating leakage during operation
- Sustains low pressure testing of 40 psi immediately upon assembly
- Easily disassembles with a small amount of cleavage force



# RETAINING COMPOUNDS

# LOCTITE<sup>®</sup> retaining compounds secure components. For strong reliable assemblies.

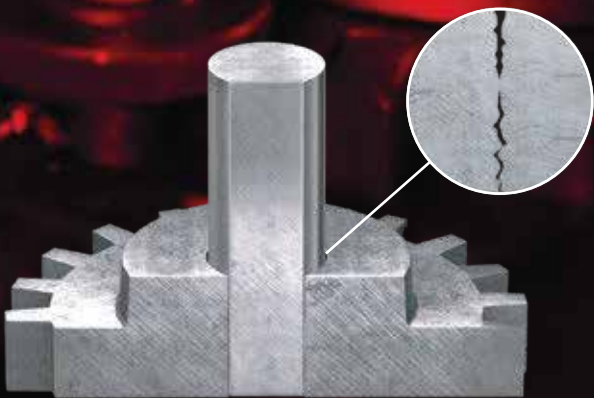

## PROBLEM

Without retaining compounds:  
Mechanical fitting methods leave gaps between fitted parts which cause cylindrical assembly failure.

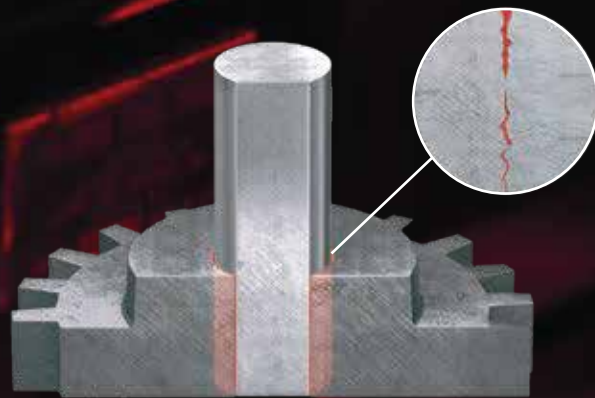

## SOLUTION

With retaining compounds:  
Gaps are unitized to provide higher torsional loads and prevent fretting corrosion.

# High loads high strength products

Retaining compounds secure bearings, keyways and cylindrical parts into housings or onto shafts, forming strong assemblies. LOCTITE® retaining compounds offer an effective and economical method to eliminate challenges like loosening, corrosion, backlash and wearing by unitizing the assembly and providing uniform stress distribution.



## How to choose a retaining compound.



### GAP SIZE

**UP TO 0.006 in.**

Typically, lower viscosity retaining compounds are used for gaps up to 0.006 in. These are typically tight fitting interference fits like those found in shrink fits.

**0.006 TO 0.010 in.**

For gaps above 0.006 in. retaining compounds with higher viscosities that allow for better gap fill are used. These include bonded slip fits.

**0.010 TO 0.020 in.**

For assemblies with large gaps that are badly worn, special paste-like retaining compounds should be used.



### TEMPERATURE RESISTANCE

Most LOCTITE® retaining compounds are able to withstand temperatures of 300° - 355°F. However, certain chemistries are available that withstand temperatures up to 450°F for assemblies which see higher service temperatures.



### STRENGTH

A high-strength retaining compound is recommended for applications that do not need to be disassembled or require extremely high torsional loads. If parts need to be taken apart for maintenance, a lower strength product should be used to aid in disassembly.





BEST SELLER

## 638™

### High Strength, Slip Fit

LOCTITE® 638™ is recommended for slip fit parts with larger gaps. Excellent performance for dynamic, axial and radial loads. Tolerates minor surface contaminants and cures on inactive metals without an activator.

 Gap: Up to .010 in.

 Temperature Resistance : 355°F

 Strength: 4,500 psi



BEST SELLER

## 660™

### Badly Worn Assemblies

LOCTITE® 660™ is designed for repairing worn coaxial parts without remachining. Enables re-use of worn bearing seats, keys, splines or tapers or for retaining shims.

 Gap: Up to .020 in.

 Temperature Resistance : 300°F

 Strength: 3,335 psi



Find the right product for your application



 GAP SIZE

**Gap Size Up To 0.006 in.**

- LOCTITE <sup>®</sup> **648**<sup>™</sup>
- LOCTITE <sup>®</sup> **641**<sup>™</sup>
- LOCTITE <sup>®</sup> **609**<sup>™</sup>

**Gap Size 0.006 to 0.010 in.**

- LOCTITE <sup>®</sup> **638**<sup>™</sup>
- LOCTITE <sup>®</sup> **620**<sup>™</sup>

**Gap Size 0.010 to 0.020 in.**

- LOCTITE <sup>®</sup> **660**<sup>™</sup>

**Gap Size up to 0.006 in.**

RETAINING COMPOUNDS



**609**<sup>™</sup>  
General Purpose



Temperature Resistance:  
300°F



Strength: 2,300 psi

Cure Speed: 24 hours  
Fixture Time: 10 minutes



**641**<sup>™</sup>  
Medium Strength



Temperature Resistance:  
300°F



Strength: 1,700 psi

Cure Speed: 24 hours  
Fixture Time: 20 minutes



**648**<sup>™</sup>  
High Strength



Temperature Resistance:  
355°F



Strength: 3,900 psi

Cure Speed: 24 hours  
Fixture Time: 3 minutes

**Gap Size - 0.006 to 0.010 in.**

RETAINING COMPOUNDS



**620**<sup>™</sup>  
High Temperature



Temperature Resistance:  
450°F



Strength: 3,800 psi

Cure Speed: 24 hours  
Fixture Time: 60 minutes



**638**<sup>™</sup>  
General Purpose



Temperature Resistance:  
355°F



Strength: 4,500 psi

Cure Speed: 24 hours  
Fixture Time: 4 minutes

**Gap Size - 0.010 to 0.020 in.**

RETAINING COMPOUNDS



**660**<sup>™</sup>  
Badly Worn Assemblies



Temperature Resistance:  
300°F



Strength: 3,335 psi

Cure Speed: 24 hours  
Fixture Time: 15 minutes

SEE THE FULL PORTFOLIO OF RETAINING COMPOUNDS AT: [retaining.loctite.us](http://retaining.loctite.us)

# Equipment RETAINING COMPOUNDS



## LOCTITE<sup>®</sup> Dual Channel Integrated Reservoir

IDH 1390321/ 1390322

This dispenser combines a dual channel dispense controller and reservoir. It provides two timing channels controlling two pneumatic outputs, such as dispense valves, advancing slides, or any other pneumatic device. Well suited for medium to high viscosity (> 3,000 cP) adhesives.



## NEW LOCTITE<sup>®</sup> Pro Pump Handheld Dispenser

IDH 2564842

Our all-new easy to use, light-weight, durable applicator that allows for precision application of threadlockers, retaining compounds and thread sealants in 50/250 ml bottles.

### ADDITIONAL EQUIPMENT

## Bond-A-Matic<sup>®</sup> 3000 Dispenser

IDH 209685/218323

## Pneumatic Handheld Applicator

IDH 88643

## Stationary Applicator Valve

IDH 88644/88645

# Surface Preparation

RETAINING COMPOUNDS



## SF 7070<sup>™</sup> Cleaner

IDH 231562

A general purpose parts cleaner formulated for metals and plastics. The product is able to remove most oils, greases, lubrication fluids, metal cuttings and dries residue free.



## SF 7649<sup>™</sup> Primer

IDH 209715

Designed to promote the curing speed of LOCTITE anaerobic adhesives and sealants without any significant loss of joint strength. Especially recommended for applications with passive metals or inert surfaces and with large bond gaps.

## RETAINING COMPOUNDS

Product	IDH Number	Pack Size	Color	Feature	Viscosity [cP]	Thixotropic (yes/ no)	Compressive Shear Strength, Steel to Steel, psi (N/mm <sup>2</sup> )	Fixture Time (min)	Temperature Range
<b>GAP SIZE – UP TO 0.006 in.</b>									
<b>609<sup>™</sup></b>	135512	50 ml	Green	Press fit, low viscosity	120	No	2,300 psi (15 N/mm <sup>2</sup> )	10	-65°F to 300°F (-54°C to 150°C)
	135513	250 ml							
<b>641<sup>™</sup></b>	231121	50 ml	Yellow	Medium strength, if disassembly is required	600	No	1,700 psi (12 N/mm <sup>2</sup> )	20	-65°F to 300°F (-54°C to 150°C)
<b>648<sup>™</sup></b>	1835920	50 ml	Green	High strength, high temperature resistance. Can be applied to slightly oily surfaces	500	No	3,900 psi (27 N/mm <sup>2</sup> )	3	-65°F to 355°F (-54°C to 180°C)
	1835918	250 ml							
<b>GAP SIZE – 0.006 TO 0.010 in.</b>									
<b>620<sup>™</sup></b>	135514	50 ml	Green	High strength, high temperature resistance	8,000	No	3,800 psi (26 N/mm <sup>2</sup> )	60	-65°F to 450°F (-54°C to 230°C)
	135515	250 ml							
<b>638<sup>™</sup></b>	1835936	50 ml	Green	High strength, high temperature resistance. Can be applied to slightly oily surfaces	2,500	No	4,500 psi (31 N/mm <sup>2</sup> )	4	-65°F to 355°F (-54°C to 180°C)
	1835925	250 ml							
<b>GAP SIZE – 0.010 TO 0.020 in.</b>									
<b>660<sup>™</sup></b>	135527	50 ml	Silver	High strength, gap fill for repair	250,000	Yes	3,335 psi (23 N/mm <sup>2</sup> )	15	-65°F to 300°F (-54°C to 150°C)



# A 5 Day Repair Reduced to 8 Hours



“We not only minimized our plant downtime on this repair, we also reduced the likelihood of future repairs and downtime.”

A loose, spinning bearing had damaged a large fan shaft at a cement manufacturer. Hardfacing and machining the shaft would have taken five days of downtime, and it could have led to future weakening and damage from distortion and fretting corrosion. The solution: LOCTITE® 638™ Retaining Compound. It fills voids, prevents fretting corrosion and evenly distributes high load stress.

A LOCTITE® Engineering Solutions Expert provided training on this new repair method, and in just 8 hours, maintenance personnel cleaned and removed the main bearing, applied LOCTITE® 638™ to the shaft, slipped the bearing into the proper position and the fan was up and running.

## BENEFITS

LOCTITE® 638™ Retaining Compound:

- Allows maintenance personnel to make efficient, in-plant repairs
- Reduces downtime
- Prevents future damage and maintains long-term repair viability



# INSTANT ADHESIVES

# Fast, lightweight, multi-material bonding.

## For more design options.

---



### PROBLEM

Without instant adhesives:  
Fastening options that  
add complexity, slow  
production or limit  
materials.



### SOLUTION

With instant adhesives:  
Strong, fast lightweight  
bonding of a wide range  
of materials.

# Bonds more material. Faster.

Instant adhesives are ideal for bonding small to medium-size parts with close fitting, smooth surfaces. They provide fast cure speeds and excellent bond strengths to a wide variety of substrates. LOCTITE instant adhesives are available in a range of formulations for anything from general purpose repairs to specialty high-performance assembly applications.



## How to choose an instant adhesive.

### GENERAL PURPOSE vs. SPECIALTY ADHESIVES

LOCTITE® has an instant adhesive formulated for any application.

**GENERAL PURPOSE** – Strong and versatile enough for the vast majority of applications, including acidic surfaces such as chromated or galvanized metals and porous substrates such as wood, paper, leather, cork and fabric.

**TOUGHENED** – Elastomer modified adhesives for applications subjected to high shock, impact and humidity.

**FLEXIBLE** – For bonding materials subjected to bending or distortion, as well as flexible components, and acidic surfaces.

**HIGH TEMPERATURE** – For applications where speed, gap filling and high temperature, humidity and vibration resistance are required.

**LOW ODOR/LOW BLOOM** – Low volatile adhesives for applications where cosmetic appearance, minimal frosting and low odor are required.

**HIGH GAP FILL** – For applications with gaps up to 0.2 inches.

**LIGHT CURE** – Designed to cure very rapidly upon exposure to UV/visible light of the proper intensity.



#### VISCOSITY

Available in viscosities from thin liquids to thixotropic, no-run gels.



#### FIXTURE SPEED

Available in various fixture speeds to accommodate applications that may require instant set times to those that may require minor adjustment time.



#### STRENGTH

Available in shear resistant, general purpose formulations to toughened, high impact, high peel resistant formulations to meet the specific strength requirements of your application.



BEST SELLER

## 401™

Fast, Medium Viscosity

LOCTITE 401™ is an instant adhesive designed for the assembly of difficult-to-bond materials requiring uniform stress distribution and high tensile and/or shear strength. The product provides for the rapid bonding of a wide range of materials, including metals, plastics and elastomers. LOCTITE 401™ is also suited to bonding porous materials such as wood, paper, leather and fabric. Perfect for all quick repairs and all types of small emergency repairs.



Viscosity: 100 cP



Fixture Speed: 5 seconds Full Cure: 24 hours



Strength: 2,900 psi



BEST SELLER

## 454™

No-Run Gel

LOCTITE 454™ is an instant adhesive designed for the assembly of difficult-to-bond materials which require uniform stress distribution and high tensile and/or shear strength. The product provides for the rapid bonding of a wide range of materials, including metals, plastics and elastomers. The no-run gel consistency enables overhead and vertical application without dripping. LOCTITE 454™ is also suited to bonding porous materials such as wood, paper, leather and fabric. Perfect for all quick repair jobs.



Viscosity: Gel



Fixture Speed: 45 seconds Full Cure: 24 hours



Strength: 3,030 psi



# Find the right product for your application



## General Purpose

- LOCTITE ° 401™
- LOCTITE ° 406™
- LOCTITE ° 495™
- LOCTITE ° 454™

## General Maintenance

- LOCTITE ° 404™

## Toughened

- LOCTITE ° 435™
- LOCTITE ° 480™

## High Temperature

- LOCTITE ° 4204™

## Flexible

- LOCTITE ° 4902™

## Low Odor / Low Bloom

- LOCTITE ° 460™
- LOCTITE ° 403™

## High Gap Fill

- LOCTITE ° 3092™

## Light Cure

- LOCTITE ° 4310™
- LOCTITE ° 4311™

**HAVE A UNIQUE APPLICATION?**  
**SEE THE FULL LINE:**  
[instant-adhesives.loctite.us](http://instant-adhesives.loctite.us)

# General Purpose

## INSTANT ADHESIVES



**401™**  
Medium Viscosity



Viscosity: 100 cP



Fixture Speed: 5 seconds  
Full Cure: 24 hours



Strength: 2,900 psi

Color: Clear  
Temperature Resistance: 250°F



**406™**  
Wicking Grade



Viscosity: 20 cP



Fixture Speed: 30 seconds  
Full Cure: 24 hours



Strength: 2,250 psi

Color: Clear  
Temperature Resistance: 250°F



**454™**  
No-Run Gel



Viscosity: Gel



Fixture Speed: 45 seconds  
Full Cure: 24 hours



Strength: 3,030 psi

Color: Clear  
Temperature Resistance: 250°F



**495™**  
Low-Medium Viscosity



Viscosity: 40 cP



Fixture Speed: 5 seconds  
Full Cure: 24 hours



Strength: 2,060 psi

Color: Clear  
Temperature Resistance: 250°F

# General Maintenance

## INSTANT ADHESIVES



**404™**  
Rubber Bonding



Viscosity: 90 cP



Fixture Speed: 20 seconds  
Full Cure: 24 hours



Strength: 3,500 psi

Color: Clear  
Temperature Resistance: 180°F

## Toughened

INSTANT ADHESIVES



**435™**  
Surface Insensitive



Viscosity: 200 cP



Fixture Speed: 30-45 seconds  
Full Cure: 24 hours



Strength: 2,700 psi

Color: Clear  
Temperature Resistance: 212°F



**480™**  
Black, High Strength



Viscosity: 200 cP



Fixture Speed: 90 seconds  
Full Cure: 24 hours



Strength: 3,800 psi

Color: Black  
Temperature Resistance: 212°F

## Low Odor / Low Bloom

INSTANT ADHESIVES



**403™**  
Gap Filling



Viscosity: 1,200 cP



Fixture Speed: 30 seconds  
Full Cure: 24 hours



Strength: 2,950 psi

Color: Pale Yellow to Colorless  
Temperature Resistance: 175°F



**460™**  
Close Fitting Parts



Viscosity: 40 cP



Fixture Speed: 20 seconds  
Full Cure: 24 hours



Strength: 3,200 psi

Color: Colorless to Straw  
Temperature Resistance: 175°F

## Thermal Resistant

INSTANT ADHESIVES



**4204™**  
High Viscosity



Viscosity: 4,000 cP



Fixture Speed: 120 seconds  
Full Cure: 24 hours



Strength: 2,400 psi

Color: Slightly Pale Yellow / Colorless  
Temperature Resistance: 250°F

## High Gap Fill

INSTANT ADHESIVES



**3092™**  
Two-component Gel



Viscosity: Gel



Fixture Speed: 210 seconds\*  
Full Cure: 24 hours



Strength: 3,200 psi

Color: Clear to Slightly Cloudy  
Temperature Resistance: 175°F

## Flexible

INSTANT ADHESIVES



**4902™**  
High Viscosity



Viscosity: 200 cP



Fixture Speed: 20 seconds  
Full Cure: 24 hours



Strength: 1,500 psi

Color: Colorless  
Temperature Resistance: 180°F

## Light Cure

INSTANT ADHESIVES



**4310™**  
Close Fitting Parts



Viscosity: 180 cP



Fixture Speed: 25\*\*



Strength: 2,950 psi

Color: Light Yellow-Green to  
Dark Blue-Green Liquid  
Temperature Resistance: 212°F



**4311™**  
Gap Filling



Viscosity: 1,000 cP



Fixture Speed: 30\*



Strength: 3,050 psi

Color: Light Yellow-Green to  
Dark Blue-Green Liquid  
Temperature Resistance: 212°F

\* Dependent upon gap size - Stated at 0.2" gap, aluminum \*\* Faster fixture times can be achieved with light cure

## Surface Preparation

INSTANT ADHESIVES



**SF 7070**™  
Cleaner, Degreaser  
IDH 231562

Color: Colorless  
Viscosity: 1.5 cP  
Base: Hydrocarbon  
Dry Time: Equivalent to water



**SF 770**™  
Polyolephin Primer  
IDH 135266

Color: Clear  
Viscosity: 1.25 cP  
Base: Heptane  
Dry Time: <30 sec.  
On-Part Life: 8 hours



**SF 7452**™  
Accelerator  
IDH 229769

Color: Clear/Amber  
Viscosity: .04 cP  
Base: Acetone  
Dry Time: <30 sec.  
On-Part Life: 1 minute



**SF 768**™  
Cleanup Solvent  
IDH 235018

Color: Clear to Yellow  
Viscosity: 1.5 cP  
Base: Nitromethane  
Dry Time: N/A

## Equipment

INSTANT ADHESIVES



**PU20 Benchtop Peristaltic Dispenser**

IDH 2265279

The LOCTITE EQ PU20 Digital Peristaltic Dispenser is a reliable and effective volumetric dispenser for single-component, low viscosity adhesives. It is great for precise dosing or applications that require a specific flow rate.



**LOCTITE ° Dual Channel Integrated Reservoir**

IDH 1390321/ 1390322

This dispenser combines a dual channel dispense controller and reservoir. It provides two timing channels controlling two pneumatic outputs, such as dispense valves, advancing slides, or any other pneumatic device. Well suited for medium to high viscosity (> 3,000 cP) adhesives.

### ADDITIONAL EQUIPMENT

**Bond-A-Matic® 3000 Dispenser**

IDH 209685/218323

**Stationary Applicator Valve**

IDH 88644/88645

**Light Cure Dispense Valve**

IDH 218280

**Low Viscosity Handheld Applicator**

IDH 444643

**Cyanoacrylate Dispense Valve**

IDH 318654

INSTANT ADHESIVES								
Product	Item Number	Pack Size	Color	Viscosity (cP)	Gap Fill	Fixture Speed, Steel (sec)	Shear Strength, GBMS	Temperature Range
<b>GENERAL PURPOSE</b>								
<b>401™</b>	135429	20 gm	Clear	100	0.005 in. (0.15 mm)	5	2900 psi (20 N/mm <sup>2</sup> )	-40°F to 250°F (-40°C to 121°C)
	135430	1 lb						
<b>406™</b>	135436	20 gm	Clear	20	0.004 in. (0.12 mm)	30	2250 psi (15.5 N/mm <sup>2</sup> )	-40°F to 250°F (-40°C to 121°C)
	237295	1 lb						
<b>454™</b>	135462	20 gm	Clear	Gel	0.01 in. (0.25 mm)	45	3030 psi (20.9 N/mm <sup>2</sup> )	-40°F to 250°F (-40°C to 121°C)
<b>495™</b>	135467	1 oz	Clear	40	0.004 in. (0.12 mm)	5	2060 psi (14.2 N/mm <sup>2</sup> )	-40°F to 250°F (-40°C to 121°C)
<b>GENERAL MAINTENANCE</b>								
<b>404™</b>	135465	0.33 oz	Clear	80	0.005 in. (0.15 mm)	20	3500 psi (24 N/mm <sup>2</sup> )	-40°F to 180°F (-40°C to 82°C)
<b>TOUGHENED</b>								
<b>435™</b>	840057	20 gm	Clear	200	0.006 in. (0.18 mm)	30-45	2700 psi (18.5 N/mm <sup>2</sup> )	-40°F to 212°F (-40°C to 100°C)
	840071	1 lb						
<b>480™</b>	135466	20 gm	Black	200	0.006 in. (0.18 mm)	90	3800 psi (26 N/mm <sup>2</sup> )	-40°F to 212°F (-40°C to 100°C)
	234048	1 lb						
<b>FLEXIBLE</b>								
<b>4902™</b>	1875841	20 gm	Colorless	200	0.004 in. (0.12 mm)	20	1500 psi (10.5 N/mm <sup>2</sup> )	-40°F to 180°F (-40°C to 82°C)
<b>HIGH TEMPERATURE</b>								
<b>4204™</b>	17544	20 gm	Slightly pale yellow/ colorless	4000	0.008 in. (0.24 mm)	120	2400 psi (16.5 N/mm <sup>2</sup> )	-40°F to 250°F (-40°C to 121°C)
	231944	1 lb						
<b>LOW ODOR / LOW BLOOM</b>								
<b>403™</b>	135433	20 gm	Pale yellow to colorless	1200	0.008 in. (0.24 mm)	30	2950 psi (20.3 N/mm <sup>2</sup> )	-40°F to 175°F (-40°C to 80°C)
	233675	1 lb						
<b>460™</b>	135463	20 gm	Colorless to straw	40	0.004 in. (0.12 mm)	20	3050 psi (21 N/mm <sup>2</sup> )	-40°F to 175°F (-40°C to 80°C)
	234020	1 lb						
<b>HIGH GAP FILL</b>								
<b>3092™</b>	1807961	11 gm	Clear to slightly cloudy	Gel	0.2 in. (5 mm)	210	3200 psi (22 N/mm <sup>2</sup> )	-40°F to 175°F (-40°C to 80°C)
<b>LIGHT CURE</b>								
<b>4310™</b>	1401792	1 oz	Light yellow-green to dark blue-green liquid	180	0.005 in. (0.15 mm)	25*	2950 psi (20.3 N/mm <sup>2</sup> )	-40°F to 212°F (-40°C to 100°C)
		1lb						
<b>4311™</b>	1401791	1 oz	Light yellow-green to dark blue-green liquid	1000	0.008 in. (0.24 mm)	30*	3050 psi (21 N/mm <sup>2</sup> )	-40°F to 212°F (-40°C to 100°C)
		1401789						

\*Note: faster fixture times can be achieved with light cure

## LOCTITE SERVICES

# REDUCE COMPLEXITY AND TIME WHILE EXPANDING DESIGN.

services.loctite.us

HOSPITAL

# Improved Appearance, Durability and Production Speed



“LOCTITE® helped make our signs more aesthetically pleasing and stronger while enabling us to ship more product faster.”

The thick bond lines and slow curing speed of a high-viscosity RTV used to bond aluminum letters to PVC sign boards was causing aesthetic issues and delaying production for a retail sign manufacturer. In addition, letters were sometimes lost due to the low bond strength of the RTV. LOCTITE® 401™ Instant Adhesive, which cures more quickly and minimizes the gap between the letters and the sign board, was an ideal solution.

A LOCTITE® Engineering Solutions Expert showed how just a few small drops of LOCTITE® 401™ on each sign letter, which was then applied to the sign board with light hand pressure, allowed the sign company to manufacture signs more quickly and provide customers with a higher quality product.

## BENEFITS

LOCTITE® 401™ Instant Adhesive:

- Minimizes gap and improves aesthetic appeal with thin bond lines
- Cures fast, maximizing production output and lowering overall production costs
- Has high bond strength that eliminates loss of sign letters and addresses customer complaints



# UNIVERSAL BONDERS

# HY 4070™ and HY 4090.™ Almost nothing they can't do.



## PROBLEM

Without Universal Bonders:  
Multiple material assemblies  
require additional primers,  
more cure time and are  
susceptible to vibration,  
temperature changes and  
humidity.



## SOLUTION

With Universal Bonders:  
Strong, durable, fast  
bonding of multiple  
materials.

# The most versatile adhesive. In your toolbox.

Faster fixture. Faster repairs.



**HY 4070™**  
Universal Bonder  
Ultra Fast Structural Adhesive

LOCTITE® HY 4070™ is a 2-part, transparent, colorless to pale yellow cyanoacrylate/acrylic hybrid gel adhesive that provides a fast fixture at room temperature in bond gaps up to 0.2 in. (5 mm). It suits various substrates including most plastics, rubbers and metals. It is used where complete cure of excess adhesive as well as temperature and moisture resistance is required.



Fixture Time: <60 seconds

Strength: 3,625 psi

Substrate: Plastic, Rubber, Metal, Wood

Product	IDH Number	Pack Size	Features	Color	Gap Fill	Viscosity [cP]	Mix Ratio	Temperature Range	Fixture Time	Lap Shear Strength, GBMS
HY 4070™	2264448	11 gm	Ultra-fast, multi-substrate bonder	Transparent to Pale Yellow	0.2 in. (5 mm)	Gel	10:1	-40°F to 212°F (-40°C to 100°C)	< 60 (aluminum, 0.05 mm gap)	3625 psi (25 N/mm²)
	2494415	45 gm								

## Dispenser

UNIVERSAL BONDRERS

Universal Dual Cartridge Manual Dispenser  
45 gm  
IDH 267452

## Nozzles

UNIVERSAL BONDRERS

11 gm IDH 1434516      45 gm IDH 1509102



**LOCTITE**  
**HY 4070™**

- High Strength combined with superfast fixture
- Outstanding substrate versatility



**SUPERFAST FIXTURE STRUCTURAL REPAIR HYBRID ADHESIVE**

ITEM NO. 2264448  
NET WT. 0.39 OZ. (11 g)





**LOCTITE**  
**HY 4090**  
HYBRID Technology

STRUCTURAL HYBRID ADHESIVE / ADHÉSIF STRUCTUREL HYBRIDE  
ADHESIVO HÍBRIDO ESTRUCTURAL

- High Strength combined with fast cure • Résistance élevée et durcissement rapide
- Excellent environmental and temperature resistance • Excellente résistance à l'environnement et à la température
- Excellent resistance to impact and vibration • Excellente résistance aux chocs et aux vibrations
- Excellent resistance to temperature fluctuations • Excellente résistance aux variations de température
- Also resistant combined with flexible resins • Aussi résistant combiné avec résines flexibles
- Excellent adhesion to various substrates • Excellente adhérence à divers matériaux

NET WT. 2.76 OZ.  
POSD. NET. 78 g

MAT / MATR. / RESIN No.  
2123350

Henkel

# Fast curing adhesives. For industrial design solutions.

Create strong and reliable bonds with HY 4090™.



## HY 4090™

Universal Bonder  
Fast & Versatile Structural Adhesive

LOCTITE HY 4090™ is an off-white to light yellow gel with high viscosity. It opens up new application areas in structural bonding by combining instant adhesive properties with those of epoxies to give more striking benefits:

- Fixture time of 90-180 seconds and suitable for gaps up to 5 mm
- Resistant to vibration, shock loads and impacts



Fixture Time: <180 seconds

Strength: 2,420 psi

Substrate: Plastic, Rubber, Metal, Wood

Product	IDH Number	Pack Size	Features	Color	Gap Fill	Viscosity [cP]	Mix Ratio	Temperature Range	Fixture Time	Lap Shear Strength, GBMS
HY 4090™	2123350	50 gm	Multi-material bonder; fast strength build; good environmental resistance	Multi-material bonder; fast strength build; good environmental resistance	0.08 in. (2 mm)	Gel	1:1	-40°F to 284°F (-40°C to 140°C)	< 180	2420 psi (17 N/mm <sup>2</sup> )
	2060035	400 gm								
HY 4090™ GY	2205827	50 gm	Multi-material bonder; fast strength build; good environmental resistance	Grey	0.08 in. (2 mm)	Gel	1:1	-40°F to 284°F (-40°C to 140°C)	< 180	2420 psi (17 N/mm <sup>2</sup> )

## Dispensers

UNIVERSAL BONDERS

Dual Cartridge Applicator  
50 ml  
Manual: IDH 720228  
Pneumatic: IDH 476898

Dual Cartridge Applicator  
400 ml  
Pneumatic: IDH 218311

## Nozzles

UNIVERSAL BONDERS

50 ml IDH 1573153  
400 ml IDH 1573135



# Fast, Durable Bonding of High Volume PA and ABS Components



“LOCTITE had the perfect adhesive solution to help bring our new product to life.”

A designer and manufacturer of battery packs for electronic devices was designing a new product and searching for an adhesive to bond PA and ABS plastics. The adhesive needed to allow for projected production line volumes and be resistant to vibration, temperature and humidity variances. LOCTITE® **HY 4090™**, a fast curing universal bonder that provides strong bonds without primers or other surface treatments, was a perfect candidate. A LOCTITE Engineering Solutions Expert showed them how to clean

battery pack parts with LOCTITE SF 7063™ to remove molding compounds that may inhibit final bond strengths, then dispense LOCTITE® **HY 4090™** from the dual cartridge packaging using the LOCTITE manual applicator equipped with a mixer nozzle. The hybrid adhesive fixtured in just 3 minutes, minimizing any potential blooming from exposed fillets of the cyanoacrylate based product, and provided a bond to PA and ABS plastics that withstood vibration, temperature and humidity variances.

## BENEFITS

LOCTITE® **HY 4090™** Universal Bonder:

- Generates strong, multi-material bonds without requiring additional surface primers
- Provides a fast fixture rate of 3 minutes that will not impede the proposed line speed
- Results in assemblies that resist vibration, temperature changes and attack by high humidity



# STRUCTURAL ADHESIVES

# Superior speed, aesthetics and strength.

## Without the weight.

---

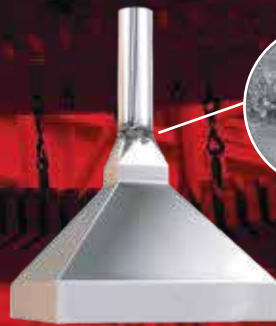

### PROBLEM

With traditional fastening:  
Added weight, time, cost  
and difficulty.



### SOLUTION

With structural adhesives:  
Lightweight, strong,  
durable, less expensive  
fastening with better end  
product aesthetics.

# Take off the weight. Take on the load.

Structural adhesives join two materials firmly and permanently using an adhesive “bridge” between the substrates. They eliminate many of the shortcomings of mechanical methods, such as:

- Improper stress distribution which can affect product reliability
- Added weight to the end-product which can increase costs

They are also easier to apply and assemble.

Selection factors to consider include adhesive-material compatibility and joint requirements.



## How to choose a structural adhesive.

### GENERAL PURPOSE vs. SPECIALTY ADHESIVES

LOCTITE® has a wide range of structural adhesives, from general purpose — strong and versatile enough to cover the majority of applications, to specialty — formulated for the rare cases where general purpose won't do.

**HIGH PERFORMANCE**  
Solutions designed for a range of product needs, with respect to impact strength, peel strength, durability, working time etc.

**FLEXIBLE SOLUTIONS**  
Offering excellent shock absorption, elasticity and adhesion to plastics, metals and glass.

**SPECIAL SUBSTRATES**  
From epoxies designed to be safe for food and water contact to acrylics and polyurethanes for bonding e-coated metals, rigid foams, plastics and glass.

**BONDING FERRITE COMPONENTS**  
Epoxies and acrylics designed for the specific requirements of bonding ferrite.

**POTTING**  
Flowable epoxies designed for filling cavities and protecting components.



#### FIXTURE SPEED

A range of fixture times from ultra fast to slow to meet your process requirements.



#### SUBSTRATE

LOCTITE® structural adhesives can bond most materials.



BEST SELLER

## EA E-20HP™

Fast Fixture, High Shear

LOCTITE EA E-20HP™ is an off-white, 2-part, toughened, medium-viscosity, industrial grade epoxy adhesive with a medium work life. The mixture cures at room temperature to form a tough bondline with high peel resistance and high shear strengths. It is resistant to a wide range of chemicals and solvents and is an excellent electrical insulator.



Fixture Speed: 120 minutes



Substrate: Concrete, Aluminum, Steel, Stainless Steel, Polyamide (Nylon), Polycarbonate, Wood



BEST SELLER

## AA 326™

Fast Fixture, Small Gaps, 2-step

LOCTITE AA 326™ is a yellow to amber, no-mix, medium viscosity (thixotropic) structural and magnet bonder which is activated with LOCTITE SF 7649™. It has good adhesion to different types of ferrites, a fixture time of 3 minutes and a shear strength of 2,200 psi. It can be used in temperatures up to 120°C.



Fixture Speed: 2 minutes



Substrate: Aluminum, Steel



# Find the right product for your application



## GENERAL PURPOSE

- LOCTITE <sup>®</sup> **AA 330**<sup>™</sup>      LOCTITE <sup>®</sup> **EA E-00CL**<sup>™</sup>
- LOCTITE <sup>®</sup> **EA E-00NS**<sup>™</sup>      LOCTITE <sup>®</sup> **EA E-05MR**<sup>™</sup>

## SPECIALTY

### High Performance

#### WORK LIFE

A range of life times from fast to slow to meet your process requirements.

#### < 1 Hour

- LOCTITE <sup>®</sup> **AA H4800**<sup>™</sup>      LOCTITE <sup>®</sup> **EA E-60HP**<sup>™</sup>
- LOCTITE <sup>®</sup> **AA H8000**<sup>™</sup>      LOCTITE <sup>®</sup> **EA E-90FL**<sup>™</sup>
- LOCTITE <sup>®</sup> **AA H8003**<sup>™</sup>      LOCTITE <sup>®</sup> **EA E-120HP**<sup>™</sup>
- LOCTITE <sup>®</sup> **EA E-20HP**<sup>™</sup>

#### ≥ 1 Hour

#### Heat Cure

- LOCTITE <sup>®</sup> **EA E-214HP**<sup>™</sup>

### Flexible Solutions

- LOCTITE <sup>®</sup> **EA E-05CL**<sup>™</sup>      LOCTITE <sup>®</sup> **U-05FL**<sup>™</sup>

### Special Substrates

- LOCTITE <sup>®</sup> **AA 3035**<sup>™</sup>      LOCTITE <sup>®</sup> **AA H8600**<sup>™</sup>

### Magnet Bonding

- LOCTITE <sup>®</sup> **AA 331**<sup>™</sup>      LOCTITE <sup>®</sup> **AA 392**<sup>™</sup>
- LOCTITE <sup>®</sup> **AA 332**<sup>™</sup>      LOCTITE <sup>®</sup> **AA 326**<sup>™</sup>

### Potting

- LOCTITE <sup>®</sup> **EA E-30CL**<sup>™</sup>      LOCTITE <sup>®</sup> **EA-40EXP**<sup>™</sup>
- LOCTITE <sup>®</sup> **EA E-60NC**<sup>™</sup>

# General Purpose

STRUCTURAL ADHESIVES



**AA 330**<sup>™</sup>  
Small Gap

THIS PRODUCT REQUIRES AN ACTIVATOR **SF 7387**<sup>™</sup>

Fixture Speed: 4 minutes

Substrate: Aluminum, Ceramic, Concrete, Glass, Metal, Stainless Steel, Steel, Wood

Gap: 0.02 in.  
Temperature Resistance: 250°F  
Color: Pale Yellow  
Chemistry: Two-step Acrylic



**EA E-00CL**<sup>™</sup>  
Fast Fixture

Fixture Speed: 15 minutes

Substrate: Aluminum, Ceramic, Concrete, Glass, Metal, Stainless Steel, Steel, Wood

Temperature Resistance: 300°F  
Color: Clear  
Chemistry: Epoxy



**EA E-00NS**<sup>™</sup>  
Non-sag

Fixture Speed: 15 minutes

Substrate: Aluminum, Ceramic, Concrete, Glass, Metal, Stainless Steel, Steel, Wood

Temperature Resistance: 300°F  
Color: Translucent  
Chemistry: Epoxy



**EA E-05MR**<sup>™</sup>  
Moisture Resistant

Fixture Speed: 15 minutes

Substrate: Aluminum, Ceramic, Concrete, Glass, Metal, Plastic, Stainless Steel, Steel, Wood

Temperature Resistance: 250°F  
Color: Ultra-Clear  
Chemistry: Epoxy

## LOCTITE SERVICES

IMPROVE STRENGTH AND AESTHETICS IN REDUCED TIME.

[services.loctite.us](http://services.loctite.us)

# High Performance

## STRUCTURAL ADHESIVES

### WORK LIFE\* < 1 HOUR



**AA H4800**™  
High Impact, PlasticBonder

Work Life: 30 minutes

Substrate: Acrylonitrile Butadiene Styrene, Aluminum, Fiberglass Reinforced Plastic (FRP), Galvanized Steel, Gel Coat, Plastic, RTM, Stainless Steel, Steel, Xenoy

Temperature Resistance: 180°F  
Color: Light Yellow  
Chemistry: Two-part Acrylic



**AA H8000**™  
High Impact, Metal Bonder

Work Life: 30 minutes

Substrate: Acrylonitrile Butadiene Styrene, Aluminum, Fiberglass Reinforced Plastic (FRP), Galvanized Steel, Gel Coat, Plastic, RTM, Stainless Steel, Steel, Xenoy

Temperature Resistance: 180°F  
Color: Green  
Chemistry: Two-part Acrylic



**AA H8003**™  
Fast Cure, High Impact

Work Life: 5 minutes

Substrate: Acrylonitrile Butadiene Styrene, Aluminum, Fiberglass Reinforced Plastic (FRP), Galvanized Steel, Gel Coat, Plastic, RTM, Stainless Steel, Steel, Xenoy

Temperature Resistance: 180°F  
Color: Green  
Chemistry: Two-part Acrylic



**EA E-20HP**™  
High Shear, High Peel

Work Life: 20 minutes

Substrate: Aluminum, Ceramic, Concrete, Glass, Metal, Steel, Stainless Steel, Wood

Fixture Speed: 120 minutes

Temperature Resistance: 350°F  
Color: Off-white  
Chemistry: Epoxy

### WORK LIFE\* ≥ 1 HOUR



**EA E-60HP**™  
High Shear, High Peel

Work Life: 60 minutes

Substrate: Aluminum, Ceramic, Concrete, Glass, Metal, Plastic, Stainless Steel, Steel, Wood

Fixture Speed: > 180

Temperature Resistance: 350°F  
Color: Off-white  
Chemistry: Epoxy



**EA E-90FL**™  
High Shear, Flexible

Work Life: 90 minutes

Substrate: Aluminum, Ceramic, Concrete, Glass, Metal, Plastic, Stainless Steel, Steel, Wood

Fixt ure Speed: > 180 minutes

Temperature Resistance: 350°F  
Color: Opaque Grey  
Chemistry: Epoxy



**EA E-120HP**™  
High Shear, Non-Sag

Work Life: 120 minutes

Substrate: Aluminum, Ceramic, Concrete, Glass, Metal, Plastic, Stainless Steel, Steel, Wood

Fixture Speed: > 180 minutes

Temperature Resistance: 350°F  
Color: Amber  
Chemistry: Epoxy

### HEAT CURE



**EA E-214HP**™  
Non Sag, High Shear

Work Life: N/A

Substrate: Acrylics, Aluminum, Glass, Nylon, Polycarbonate, PVC, Stainless Steel

Fixture Time: N/A

Temperature Resistance: 300°F  
Color: Grey  
Chemistry: 1-Part-Epoxy

\*Work Life = maximum time before assembly

## Flexible Solutions

STRUCTURAL ADHESIVES



**EA E-05CL**™  
Fast Fixture

Work Life: 5 minutes

Substrate: Aluminum, Ceramic, Concrete, Glass, Metal, Plastic, Stainless Steel, Steel, Wood

Fixture Speed: 30 minutes

Temperature Resistance: 300°F  
Color: Clear  
Chemistry: Epoxy



**UK U-05FL**™  
High Peel

Work Life: 5 minutes

Substrate: Aluminum, Ceramic, Concrete, Glass, Metal, Plastic, Stainless Steel, Steel, Wood

Fixture Speed: 160 minutes

Temperature Resistance: 300°F  
Color: Off-White  
Chemistry: Polyurethane

## Special Substrates

STRUCTURAL ADHESIVES



**AA 3035**™  
Polyolefin

Work Life: 5 minutes

Substrate: Polyolefin

Temperature Resistance: 180°F  
Color: Pale Yellow  
Chemistry: Two-part Acrylic



**AA H8600**™  
Galvanized Steel

Work Life: 25 minutes

Substrate: Galvanized Steel

Temperature Resistance: 250°F  
Color: Blue  
Chemistry: Two-part Acrylic

## Magnet Bonding

STRUCTURAL ADHESIVES



**AA 331**™  
Ultra Fast Fixture

THIS PRODUCT REQUIRES AN ACTIVATOR **SF 7387**™

Fixture Speed: 20 seconds

Substrate: Metal

Gap: 0.02 in.  
Temperature Resistance: 350°F  
Color: Light to sand yellow  
Chemistry: Two-step Acrylic



**AA 332**™  
High Temp Resistance

THIS PRODUCT REQUIRES AN ACTIVATOR **SF 7387**™

Fixture Speed: 3 minutes

Substrate: Magnets

Gap: 0.02 in.  
Temperature Resistance: 400°F  
Color: Amber  
Chemistry: Two-step Acrylic



**AA 392**™  
Medium Viscosity

THIS PRODUCT REQUIRES AN ACTIVATOR **SF 7387**™

Fixture Speed: 1 minute

Substrate: Metal

Gap: 0.02 in.  
Temperature Resistance: 250°F  
Color: Amber  
Chemistry: Two-step Acrylic



**AA 326**™  
High Viscosity

THIS PRODUCT REQUIRES AN ACTIVATOR **SF 7649**™

Fixture Speed: 2 minutes

Substrate: Metal

Gap: 0.02 in.  
Temperature Resistance: 250°F  
Color: Light Amber  
Chemistry: Two-step Acrylic

## Potting

STRUCTURAL ADHESIVES



**EA E-30CL**™  
Water Resistant, Clear

Work Life: 30 minutes

Substrate: Ceramics, Glass, Metals, Optical Fibers, Rigid Plastics

Fixture Speed: 180 minutes

Temperature Resistance: 350°F  
Color: Clear  
Chemistry: Epoxy



**EA E-40EXP**™  
Explosion Proof

Work Life: 40 minutes

Substrate: Ceramics, Glass, Metals, Optical Fibers, Rigid Plastics

Fixture Speed: N/A

Temperature Resistance: 300°F  
Color: Black  
Chemistry: Epoxy



**EA E-60NC**™  
Non-corrosive

Work Life: 60 minutes

Substrate: Ceramics, Glass, Metals, Optical Fibers, Rigid Plastics

Fixture Speed: >180 minutes

Temperature Resistance: 250°F  
Color: Black  
Chemistry: Epoxy

# Equipment

STRUCTURAL ADHESIVES

## DISPENSERS



### 50 ml

Dual Cartridge  
Applicators  
1:1, 2:1, 4:1  
Manual: IDH 720228  
Pneumatic: IDH 476898

### 50 ml

Dual Cartridge  
Applicators  
10:1 S-Style  
1:1, 2:1, 4:1  
Manual: IDH 1034026  
Pneumatic:  
IDH 1493310

### 200 ml

Dual Cartridge  
Applicators  
1:1, 2:1  
Manual: IDH 218312  
Pneumatic: IDH 218311

### 490 ml

10:1  
Pneumatic: IDH 470572

HAVE A UNIQUE APPLICATION? SEE THE FULL LINE:  
[structurals.loctite.us](http://structurals.loctite.us)



STRUCTURAL ADHESIVES - 2-STEP ACRYLICS									
Product	IDH Number	Pack Size	Features	Color	Viscosity [mPa-s, cP]	Gap Fill	Fixture Time [min]	Shear Strength, GBMS	Temperature Resistance
<b>GENERAL PURPOSE</b>									
<b>AA 326™</b>	135402	50 ml	Ferrites to plated materials in electric motors, loudspeakers hardware, jewelry	Transparent, yellow to light amber	18,000	0.02 in. [0.5 mm]	2	2200 psi [15 N/mm <sup>2</sup> ]	32°F to 250°F (0°C to 120°C)
<b>AA 330™</b>	1690727	25 ml kit	Metal, wood, ferrite, ceramic, plastic	Cloudy, colorless to pale yellow	65,000	0.02 in. [0.5 mm]	4	3300 psi [23 N/mm <sup>2</sup> ]	32°F to 250°F (0°C to 120°C)
<b>AA331™</b>	1057673	25 ml	Non-corrosive, high temp resistance, high shear and impact, toughened. DC motor assembly, magnet bonding	Light yellow to sand yellow	30,000	0.02 in. [0.5 mm]	20 seconds	3100 psi [21 N/mm <sup>2</sup> ]	32°F to 350°F (0°C to 175°C)
<b>AA 332™</b>	232743	300 ml	Securing permanent magnets in motors	Opaque light yellow to dark amber	100,000	0.02 in. [0.5 mm]	3	3000 psi [20 N/mm <sup>2</sup> ]	32°F to 400°F (0°C to 200°C)
<b>MAGNET BONDING</b>									
<b>AA 392™</b>	232853	25 ml	Rapic cure. Ideal for DC motor assembly, magnet bonding, pre-coated sheet metal	Translucent beige to dark amber	12,000	0.02 in. [0.5 mm]	1	2500 psi [17 N/mm <sup>2</sup> ]	32°F to 250°F (0°C to 120°C)

STRUCTURAL ADHESIVES - 2-PART ACRYLICS										
Product	IDH Number	Pack Size	Features	Color	Viscosity [mPa-s, cP]	Mix Ratio	Work Time** (min)	Lap Shear Strength	Impact Strength, Steel [joules]	Peel Strength, Steel
<b>GENERAL METAL BONDERS</b>										
<b>AA H800™</b>	411833	490 ml	Non-sag, superior impact and peel strength, little to no surface prep, rapid room temp cure, excellent environmental resistance	Green	8,850	10:1	30	2800 psi [20 N/mm <sup>2</sup> ]	23	45 pli [8 N/mm]
<b>AA H8003™</b>	2244127	490 ml	Superior impact and peel strength; little/no surface prep; rapid room temp cure; excellent environmental resistance; contains 10ml spacer	Green	20,000 - 50,000	10:1	5	3300 psi [23 N/mm <sup>2</sup> ]	14	15 pli [2 N/mm]
<b>AA H860™</b>	2060835	400 ml	Superior impact and peel strength; little/no surface prep; rapid room temp cure; excellent environmental resistance; contains 10ml spacer	Green	20,000 - 50,000	10:1	5	3300 psi [23 N/mm <sup>2</sup> ]	14	15 pli [2 N/mm]
<b>PLASTIC AND COMPOSITE BONDERS</b>										
<b>AA 3035™</b>	1677288	50 ml	Fast fixture time; bonds to low energy plastics	Pale yellow	14,000	1:1	5	365 psi [2.5 N/mm <sup>2</sup> ]	5.8****	45 pli [8 N/mm]
<b>AA H480™</b>	2061246	490 ml	Excellent environmental resistance and tolerance to off-ratio mixing; superior impact and peel strength; non-sag gaps	Light yellow	50,000	10:1	30	2300 psi [16 N/mm <sup>2</sup> ]	27 GBMS, 72 hr	80 pli [14 N/mm]

\*\*5 Working time = maximum time before assembly  
 \*\*\*Galvanized steel  
 \*\*\*\*HDPE

## STRUCTURAL ADHESIVES - EPOXIES

Product	IDH Number	Pack Size	Features	Color	Viscosity (cP)	Mix Ratio	Fixture Time [min]	Lap Shear Strength, Steel	Temperature Resistance
<b>HIGH PERFORMANCE</b>									
<b>EA E-20HP™</b>	237107	50 ml	Excellent bond strength to plastics, metals, dry concrete, limestone	Off-white	30,000	2:1	120	3200 psi [22 N/mm <sup>2</sup> ]	-40°F to 350°F (-40°C to 175°C)
	237109	400 ml							
<b>EA E-30CL™</b>	237116	50 ml	Excellent bond strength to plastics, metals, dry concrete, limestone	Off-white	30,000	2:1	120	3200 psi [22 N/mm <sup>2</sup> ]	-40°F to 350°F (-40°C to 175°C)
	237118	400 ml							
<b>EA E-40EXP™</b>	1511653	200 ml	Potting electric motors	Black	20,000	2:1	N/A	2060 psi [14 N/mm <sup>2</sup> ]	-40°F to 300°F (-40°C to 150°C)
<b>EA E-60HP™</b>	237110	50 ml	Extended work life	Off-white	45,000	2:1	> 180	4320 psi [30 N/mm <sup>2</sup> ]	-40°F to 350°F (-40°C to 175°C)
<b>EA E-60NC™</b>	237113	50 ml	Bonding, potting, encapsulating electrical components	Black opaque	8,000	1:1	> 180	2360 psi [16 N/mm <sup>2</sup> ]	-40°F to 250°F (-40°C to 120°C)
	237115	400 ml							
<b>EA E-90FL™</b>	219298	50 ml	Resistant to range of chemicals/solvents; excellent electrical insulator; extended work life; plastic, metal, glass, wood, ceramic, rubber, masonry	Grey	40,000	1:1	> 180	810 psi [6 N/mm <sup>2</sup> ]	-40°F to 350°F (-40°C to 175°C)
	237106	400 ml							
<b>EA E-120HP™</b>	237128	50 ml	High impact and peel strength; aerospace applications, aluminum, steel, plastics, ceramics	Amber-beige	30,000	2:1	> 180	4300 psi [30 N/mm <sup>2</sup> ]	-40°F to 350°F (-40°C to 175°C)
	237130	400 ml							
<b>FAST FIXTURE</b>									
<b>EA E-00CL™</b>	237095	50 ml	General purpose bonding, potting, or encapsulating	Clear	10,000	1:1	15	2200 psi [15 N/mm <sup>2</sup> ]	-40°F to 300°F (-40°C to 150°C)
<b>EA E-00NS™</b>	233962	50 ml	Excellent electrical insulator	Translucent white to yellow paste	100,000	1:1	15	1600 psi [11 N/mm <sup>2</sup> ]	-40°F to 300°F (-40°C to 150°C)
<b>EA E-05CL™</b>	237099	50 ml	Ideal for bonding when flexibility is needed	Clear	2,500	1:1	30	1450 psi [10 N/mm <sup>2</sup> ]	-40°F to 300°F (-40°C to 150°C)
<b>EA E-05MR™</b>	1086598	50 ml	Forms ultra clear bond line with excellent impact resistance	Water white clear liquid	25,000	1:1	15	3400 psi [23 N/mm <sup>2</sup> ]	-40°F to 250°F (-40°C to 120°C)
	1086599	400 ml							
<b>ONE PART</b>									
<b>EA E-214HP™</b>	234001	300 ml	Excellent peel resistance and impact strength	Light grey paste	Paste	One Component	N/A	4800 psi [33 N/mm <sup>2</sup> ]	-40°F to 350°F (-40°C to 175°C)

## STRUCTURAL ADHESIVES - POLYURETHANE

Product	IDH Number	Pack Size	Features	Color	Viscosity [mPa-s, cP]	Gap Fill	Fixture Time [min]	Shear Strength, GBMS	Temperature Resistance
<b>UK U-05FL™</b>	261797	50 ml	Potting and encapsulating strain and heat-sensitive electronic components	Off-white	100,000	1:1	160	930 psi [6 N/mm <sup>2</sup> ]	-40°F to 300°F (-40°C to 150°C)
	237127	400 ml							

LOCTITE® E20HP™ STRUCTURAL ADHESIVE



# A Long-Lasting Alternative to Welding



“LOCTITE® helped us find a solution to constant spot weld failures that were costing us equipment downtime and repair costs.”

A paper recycler’s stainless steel filter screens failed regularly in service – every 6 to 8 weeks – due to the erosion of spot welds that caused the mesh to fall into the rotating screen system. The frequent replacement required by these failures caused equipment downtime and labor costs.

LOCTITE® **E-20HP™**, a structural adhesive that is resistant to peel and shear forces, was the perfect solution. A LOCTITE Engineering Solutions Expert walked the team through the process, from ground

washing the screen mesh and filter to remove any paper recycling debris and chemical residues, to dispensing from a 50 ml. dual cartridge, to positioning and weighting the replacement mesh. The new process has lowered filter replacement costs, labor repair costs and doubled uptime between process downtime, thereby increasing recycling production output.

## BENEFITS

LOCTITE® **E-20HP™** Structural Adhesive:

- Provides the needed durability to withstand the abrasive forces in the filter process
- Replaces spot welds and holds the fine filter mesh in place for more than 16 weeks
- Offers cost savings by reducing equipment down time and labor costs

# FLEXIBLE ADHESIVES AND SEALANTS



# Varied substrates. High elongation.

## For joints with high movement.

---

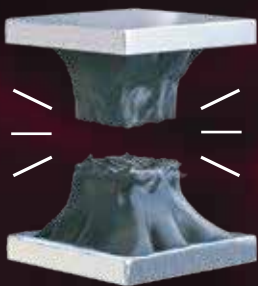

### PROBLEM

Without flexible adhesives:  
Joints may fail under  
dynamic stresses.



### SOLUTION

With flexible adhesives:  
Joints compensate for  
movement.

# Bonding and sealing for dynamic loads.

Flexible adhesives and sealants are ideal for applications that are subjected to dynamic forces and require durable adhesion to a variety of substrates. They fill large gaps and once cured, their resilient properties provide UV-resistant, waterproof seals and strong bonds that withstand high tensile and impact forces, as well as cold and hot temperature cycles, where substrates expand and contract at different rates.



## How to choose a flexible adhesive or sealant.

### BONDING vs. SEALING

While all of the flexible adhesives and sealants provide both a bond and a seal, some are formulated with higher tensile strengths which make them better suited for bonding applications. Alternatively, others are developed with higher elongation properties, which make them more ideally suited for sealing applications.



#### PAINTABILITY

SMP\*-based adhesives and sealants are paintable immediately after application, while silicone-based adhesives and sealants are not compatible with paint.



#### TEMPERATURE

The operating temperature requirements of your end device may have an impact on which flexible adhesive and sealant is best suited for your application.



#### CURE SPEED

Two-component flexible adhesive and sealants provide fast cure times, while one-component products rely on ambient moisture and require longer times to cure.

\*Silane Modified Polymer



BEST SELLER

## TEROSON<sup>®</sup> MS 939NA<sup>™</sup>

Primerless, Multi-purpose Adhesive

TEROSON<sup>®</sup> MS 939<sup>™</sup> is an industrial elastomeric bonding adhesive that offers high versatility. The product demonstrates both high strength and good elasticity. TEROSONMS 939<sup>™</sup> meets the damp heat test for the solar industry and the UL listing for electrical equipment. It has excellent weathering resistance.



Paintability: Yes



Temperature Resistance: 212°F



Cure Speed: 24 hours



BEST SELLER

## TEROSON<sup>®</sup> MS 930NA<sup>™</sup>

Primerless Sealant/Adhesive

TEROSON<sup>®</sup> MS 930<sup>™</sup> is a 1-part, white, grey or black, moisture-cured, thixotropic silane modified polymer sealant/adhesive. It is suitable for various applications involving a wide range of substrate materials. It forms a soft elastic product and provides excellent UV and weathering resistance. It complies with UL QMFZ2 for electrical safety.



Paintability: Yes



Temperature Resistance: 175°F



Cure Speed: 24 hours



Find the right product for your application



**Flexible Adhesives**

**TEROSON MS 939NA™**  
**TEROSON MS 9399™**

**Flexible Sealants**

**LOCTITE® SI 595™**  
**LOCTITE® SI 593™**  
**TEROSON® MS 930NA™**  
**TEROSON® MS 5510™**

**Flexible Adhesives**



**TEROSON® MS 939NA™**  
One-component, SMP\*



**TEROSON® MS 9399™**  
Two-component, SMP\*



Paintability: Yes



Paintability: Yes



Temperature Resistance: 212°F



Temperature Resistance: 212°F



Cure Speed: 24 hours  
Skin Over Time: 5 min.



Cure Speed: 3 hours  
Skin Over Time: 25 min.

Color: Black, White, Grey  
Cure Method: Moisture  
Tensile Strength: 400 psi

Color: Component A: Black, Grey, White,  
Component B: Black, White  
Cure Method: 2-component Mix  
Tensile Strength: 400 psi

**Equipment**

FLEXIBLE ADHESIVES AND SEALANTS



**Manual Cartridge Applicator, 300 ml**

IDH 1093940

The LOCTITE brand Manual Cartridge Applicator is designed for use with sealants and adhesives packaged in 300 ml cartridges. The mechanical advantage of a 26:1 thrust ratio allows for easy application of medium to high viscosity materials.



**HD10 300 ml Pneumatic Cartridge Dispenser**

IDH 1714379

The LOCTITE HD10 Pneumatic Hand-Held Cartridge Dispenser is a manually controlled applicator that dispenses product from 300 ml cartridges or 250 ml tubes (when tube adapter 989347 is used). The cartridge or tube is pneumatically pressurized and product is dispensed from the nozzle while the trigger is depressed.

**ADDITIONAL EQUIPMENT**

**400 ml**

Dual Cartridge Dispenser

Manual: IDH 218312

Pneumatic: IDH 218311

# Flexible Sealants



**LOCTITE<sup>®</sup>**  
**SI 595<sup>™</sup>**  
General Purpose

Paintability: No

Temperature Resistance: 450°F

Cure Speed: 24 hours  
Tack-Free Time: 30 min.

Color: Clear  
Cure Method: Moisture  
Tensile Strength: 200 psi



**LOCTITE<sup>®</sup>**  
**SI 593<sup>™</sup>**  
General Purpose

Paintability: No

Temperature Resistance: 450°F

Cure Speed: 24 hours  
Tack-Free Time: 30 min.

Color: Black  
Cure Method: Moisture  
Tensile Strength: 200 psi



**TEROSON<sup>®</sup>**  
**MS 930NA<sup>™</sup>**  
One-component, SMP\*

Paintability: Yes

Temperature Resistance: 175°F

Cure Speed: 24 hours  
Skin Over Time: 25 min.

Color: White, Grey, Black  
Cure Method: Moisture  
Tensile Strength: 200 psi



**TEROSON<sup>®</sup>**  
**MS 5510<sup>™</sup>**  
One-component, SMP\*

Paintability: No

Temperature Resistance: 212°F

Cure Speed: 24 hours  
Skin Over Time: 35 min.

Color: Black Paste  
Cure Method: Moisture  
Tensile Strength: 200 psi

## FLEXIBLE ADHESIVES

Product	IDH Number	Pack Size	Color	Features	Extrusion Rate [g/min]	Technology	Skin Over Time [minutes]	Temperature Range	Shore Hardness	Tensile Strength [psi]	Elongation at Break [%]	Lap Shear Strength on Steel [psi]
<b>TEROSON MS 939NA<sup>™</sup></b>	2068378	290 ml	Black	Primerless, good UV/ weather resistance, paintable, solvent/ isocyanate-free	20	Silane Modified Polymer	5	-40°F to 212°F (-40°C to 100°C)	A 55	400	500	270
<b>TEROSON MS 9399<sup>™</sup></b>	2081197	50 ml	White	Non-sag, high tack, fast set time	NA	Silane Modified Polymer	30	-40°F to 212°F (-40°C to 100°C)	A 55	400	150	270
	2081666	400 ml										

## FLEXIBLE SEALANTS

<b>LOCTITE<sup>®</sup></b> <b>SI 593<sup>™</sup></b>	193996	80 ml	Black	Good resistance to extreme thermal and UV cycling without hardening, shrinking or cracking	100	Silicone	30	-65°F to 450°F (-55°C to 232°C)	A 20	200	300	NA
	193997	300 ml										
<b>LOCTITE<sup>®</sup></b> <b>SI 595<sup>™</sup></b>	160809	80 ml	Clear	Good resistance to extreme thermal and UV cycling without hardening, shrinking or cracking	550	Silicone	30	-65°F to 450°F (-55°C to 232°C)	A 15	200	275	NA
	193999	300 ml										
<b>TEROSON<sup>®</sup></b> <b>MS 930NA<sup>™</sup></b>	2138430	290 ml	White	Primerless, good UV/ weather resistance, paintable, solvent/ isocyanate-free	300	Silane Modified	25	-60°F to 175°F (-50°C to 80°C)	A 30	200	380	145
	2138431		Black									
<b>TEROSON<sup>®</sup></b> <b>MS 5510<sup>™</sup></b>	1560557	300 ml	Black	Outstanding adhesion and toughness; for bonding/sealing dissimilar substrates subjected to joint movement or impact	375	Silane Modified Polymer	35	-40°F to 212°F (-40°C to 100°C)	A 40	200	375	230
	1562040		Clear									
	1562042		White									
	1562044		Grey									

**HAVE A UNIQUE APPLICATION?  
SEE THE FULL LINE:  
[flexible-adhesives.loctite.us](http://flexible-adhesives.loctite.us)**

LOCTITE® TEROSON® MS 930™ FLEXIBLE ADHESIVE



# A Single Flexible Option to Replace Other Elevator Door Fasteners



“LOCTITE® reduced our elevator door production time and cost, while improving product quality.”

Manufacturers of elevators and elevator components have discovered that LOCTITE® Teroson® **MS 930™** Flexible Adhesive allows them to replace everything from other adhesives to welded connections with a single solution that performs better and is faster, easier and safer to apply. A LOCTITE Engineering Solutions Expert helped one elevator door manufacturer replace spot welding operations for internal door supports with LOCTITE® Teroson® **MS 930™** to improve product quality and

simplify the assembly process. Another manufacturer designing a new elevator door jamb learned how to use LOCTITE® Teroson® **MS 930™** to replace a competitor’s adhesive tape that required a flammable solvent primer to apply, resulting in improved plant safety and increased production output. Both manufacturers substantially reduced materials cost as well.

## BENEFITS

LOCTITE® Teroson® **MS 930™**  
Flexible Adhesive:

- Silane modified polymer technology that meets all local health and safety requirements
- Disperses joint load distribution over the entire flange versus spot weld contact points
- Reduces plant power consumption compared to welding
- Does not deform the metal surface and eliminates refinishing required after welding operations
- Improves plant safety by eliminating flammable solvent primer
- Increases production output by up to 90% with faster dispensing speed and assembly
- Provides material cost savings of as much as 27% compared to adhesive tape



# LIGHT CURE ADHESIVES

Strength.  
Transparency.  
Rapid curing.  
For faster  
process speeds.

---

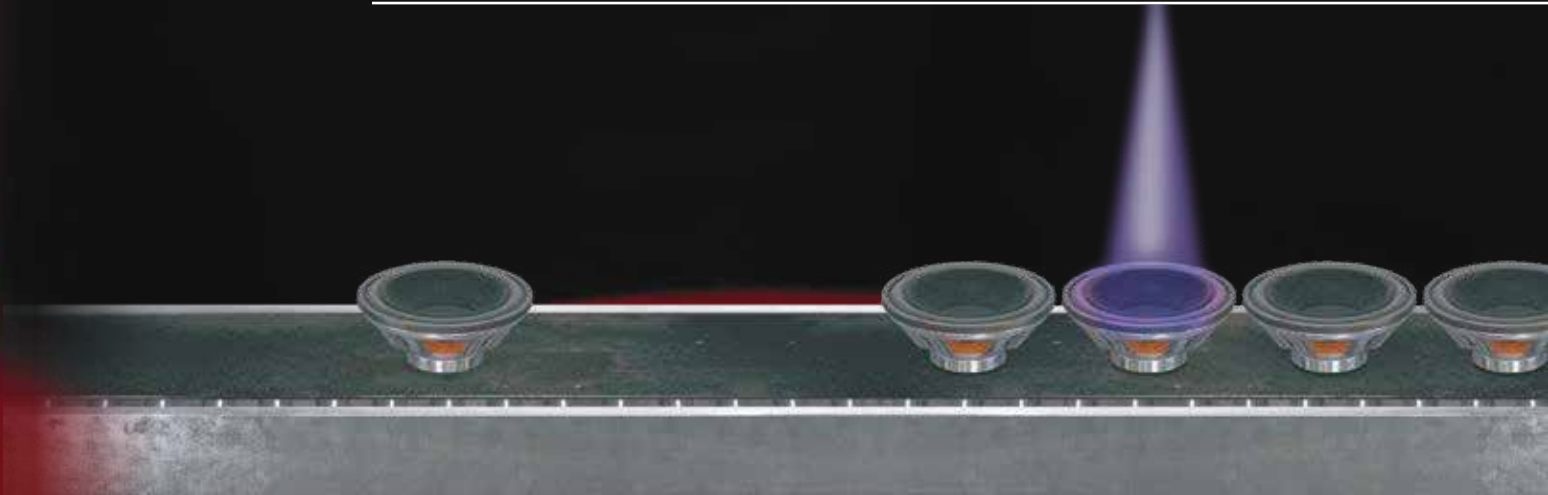

PROBLEM

Without light cure adhesives: Longer cure times and slower processing.

SOLUTION

With light cure adhesives: High speed cure on demand.

# Excellent bonding. Fast processing.

Light cure adhesives are ideal for applications requiring fast production speeds and are commonly used in the assembly of glassware, loudspeakers, optical instruments, electrical components, and disposable medical devices. To help select the best product for your application, key considerations include the ability of the assembled parts to transmit the UV/visible light to the bond line, whether a rigid or flexible bond line is required, and the types of substrates being bonded.



## How to choose a light cure adhesive.



### LIGHT TRANSPARENT SUBSTRATE vs. OPAQUE

Use visible light cure adhesives for UV-stabilized, transparent substrates. For opaque substrates, dual cure adhesives expand the benefits of light cure technology to non-transparent substrates and other application areas.



### BOND TYPE

#### FLEXIBLE

Highly flexible bonds that offer high thermal cycle resistance and are suitable for elastic bonding, sealing and leak-proofing.

#### RIGID

High-strength adhesives that cure quickly and provide tough bond lines that are suitable for bonding rigid plastics and metals.



### SUBSTRATE

Many light cure adhesives are specially formulated to provide optimum performance on specific substrates, so the adhesive is best suited for the intended application.





BEST SELLER

## AA 3953™

Ultra Fast, Plastic Bonding, Medium Viscosity

LOCTITE AA 3953™ is a medium viscosity light cure adhesive designed for applications where a fast curing, highly flexible adhesive is required. It is an optimal choice when bonding plasticized PVC, TPEs and thermoset rubbers.

 Bond: Flexible

 Substrate: Plastic, TPE





BEST SELLER

## AA 3494™

Glass Bonding

LOCTITE 3494™ is a clear, medium viscosity, acrylic-based adhesive that sets in seconds when exposed to the proper UV/visible light intensity. The adhesive is ideal for bonding glass, plastic and metal parts, and provides an impact resistant bond that withstands prolonged exposure to humidity and water immersion.

 Bond: Semi-rigid

 Substrate: Glass, Metal



Find the right product for your application



### Transparent Substrates

- LOCTITE® AA 3922™
- LOCTITE® AA 3951™
- LOCTITE® AA 3953™
- LOCTITE® AA 3961™
- LOCTITE® AA 3963™
- LOCTITE® AA 3494™
- LOCTITE® AA 3462™

### Opaque Substrates

- LOCTITE® 4310™
- LOCTITE® 4311™
- LOCTITE® SI 5031™
- LOCTITE® SI 5039™
- LOCTITE® AA 352™

HAVE A UNIQUE APPLICATION?  
SEE THE FULL LINE:  
[light-cure.loctite.us](http://light-cure.loctite.us)

## Transparent Substrates

LIGHT CURE ADHESIVES



**AA 3961™**  
Ultra Fast, Tack-Free,  
Low Viscosity



Bond: Rigid



Substrate: Metals, Plastics,  
Stainless Steel, Polycarbonate,  
ABS, Acrylic, HDPE, PP

Chemistry: Acrylic  
Viscosity: 80 cP  
**Compliant with ISO 10993:** Yes  
Fluorescence: Yes  
Color: Transparent, Colorless to Straw



**AA 3951™**  
Ultra Fast, Plastic Bonding,  
Low Viscosity



Bond: Flexible



Substrate: Plasticized PVC,  
TPEs, Thermoset Rubbers,  
Polycarbonate, ABS, Acrylic,  
HDPE, PP

Chemistry: Acrylic  
Viscosity: 150 cP  
**Compliant with ISO 10993:** Yes  
Fluorescence: Yes  
Color: Transparent, Colorless to Straw



**AA 3922™**  
General Purpose,  
Medium Viscosity



Bond: Semi-rigid



Substrate: Stainless Steel

Chemistry: Acrylic  
Viscosity: 300 cP  
**Compliant with ISO 10993:** Yes  
Fluorescence: Yes  
Color: Transparent to Hazy



**AA 3963™**  
Ultra Fast, Tack-Free,  
Medium Viscosity



Bond: Rigid



Substrate: Metals, Plastics,  
Stainless Steel, Polycarbonate,  
ABS, Acrylic, HDPE, PP

Chemistry: Acrylic  
Viscosity: 350 cP  
**Compliant with ISO 10993:** Yes  
Fluorescence: Yes  
Color: Transparent, Colorless to Straw

## Opaque Substrates

LIGHT CURE ADHESIVES



**4310™**  
Ultra Fast, Low Viscosity



Bond: Rigid



Substrate: Plastics, Rubbers,  
Metals

Chemistry: Cyanoacrylate  
Viscosity: 175 cP  
**Compliant with ISO 10993:** Yes  
Fluorescence: Yes  
Color: Clear/Pale Green



**4311™**  
Ultra Fast,  
Medium Viscosity



Bond: Rigid



Substrate: Plastics, Rubbers,  
Metals

Chemistry: Cyanoacrylate  
Viscosity: 1,050 cP  
**Compliant with ISO 10993:** Yes  
Fluorescence: Yes  
Color: Clear/Pale Green



**AA 3953**™  
Ultra Fast, Plastic Bonding,  
Medium Viscosity



Bond: Flexible



Substrate: Plasticized PVC,  
TPEs, Thermoset Rubbers,  
Polycarbonate, ABS, Acrylic,  
HDPE, PP

Chemistry: Acrylic  
Viscosity: 550 cP  
**Compliant with ISO 10993:** Yes  
Fluorescence: Yes  
Color: Transparent, Colorless to Straw



**AA 3494**™  
Glass Bonding



Bond: Semi-rigid



Substrate: Glass

Chemistry: Acrylic  
Viscosity: 6,000 cP  
**Compliant with ISO 10993:** No  
Fluorescence: No  
Color: Transparent



**AA 3462**™  
Glass Bonding,  
Environmental Resistant



Bond: Rigid



Substrate: Glass, Metals,  
Coated Metals

Chemistry: Acrylic  
Viscosity: 12,000 cP  
**Compliant with ISO 10993:** No  
Fluorescence: No  
Color: Colorless to Light Yellow



**AA 352**™  
Toughened



Bond: Rigid



Substrate: Metal, Glass

Chemistry: Acrylic  
Viscosity: 20,500 cP  
**Compliant with ISO 10993:** No  
Fluorescence: No  
Color: Clear/Light Amber



**SI 5031**™  
Potting, Encapsulating



Bond: Highly Flexible



Substrate: Glass, Metal, Ceramic

Chemistry: Silicone  
Viscosity: 5,500 cP  
**Compliant with ISO 10993:** No  
Fluorescence: No  
Color: Translucent



**SI 5039**™  
Gasketing, Sealing  
(self-leveling paste)



Bond: Highly Flexible



Substrate: Glass, Metal, Ceramic

Chemistry: Silicone  
Extrusion Rate: 220 g/min  
**Compliant with ISO 10993:** No  
Fluorescence: Yes  
Color: Translucent/Colorless/Fluorescent



## Equipment DISPENSING



### Manual Syringe Dispenser , 30 ml

IDH 1544934

A hand-held, manually operated dispenser, for any product packaged in a standard 30 ml syringe. This dispenser provides a convenient, cost-effective method to apply product.



### Digital Syringe Dispenser

IDH 883976

A semi-automatic dispensing system designed to dispense LOCTITE adhesives and fluids packaged in 3, 5, 10, 30, 55 syringes and 300 ml cartridges. The unit has digital timing control with decimal settings to 0.001 seconds for increased precision over typical pressure-time systems. An adjustable pressure regulator controls a pulse of air, and when used in conjunctions with an air line adapter attached to an adhesive syringe barrel, will provide a controlled dispensed amount of adhesive.

#### ADDITIONAL EQUIPMENT

### Dual Channel Integrated Reservoir

IDH 1390321/1390322

### Pneumatic Handheld Applicator

IDH 88643

### Stationary Applicator Valve

IDH 88644/88645

### Light Cure Dispense Valve

IDH 218280

### EQ VA20 Volumetric Valve

IDH 2084141

## Equipment CURING



### EQ CL32 LED Spot

IDH 2182207/2182210

A high powered, portable LED light source that offers a high level of flexibility for all UV or visible light curing needs. The light weight, compact design helps minimize operator fatigue, while its small size and long focus length make it perfect for applications in crowded areas and hard to reach bond areas.



### EQ CL25 LED Spot System

- Controller, IDH 1786127
- EQ CL25 405 nm LED Head, IDH 2104788
- EQ CL25 365 nm LED Head, IDH 1984957

#### ADDITIONAL EQUIPMENT

### EQ CL28 CureJet® LED Spot System

- Single CureJet® Controller, IDH 1364033
- Quad CureJet® Controller, IDH 1180632
- EQ CL28 CureJet® 405 nm Spot Head, IDH 2183340
- EQ CL28, CureJet® 380 nm Spot Head, IDH 2183339

### EQ CL30 LED Flood System

- Single Flood Controller, IDH 1359255
- Quad Flood Controller, IDH 2257357
- EQ CL30 405 nm Flood Head, IDH 2139180
- EQ CL30 380 nm Flood Head, IDH 2139181
- EQ CL30 365 nm Flood Head, IDH 2139182

### EQ CL15 UV Wand System

- EQ CL15 UV Wand System Controller, IDH 1661548
- EQ CL15 Light Guide, 1M Single Pole, IDH 376745

HAVE A UNIQUE APPLICATION? SEE THE FULL LINE:  
[light-cure.loctite.us](http://light-cure.loctite.us)

## LIGHT CURE ADHESIVES

Product	IDH Number	Pack Size	Appearance	Cure Type	Key Substrates	Viscosity, mPa-s (cP)	Temperature Range	Hardness	Block Shear Strength, PC
<b>TRANSPARENT SUBSTRATES</b>									
<b>AA 3462™</b>	2248420	1 liter	Translucent, colorless to light yellow liquid	Ultraviolet (UV)/ visible light	Glass, metals, coated metals	12,000	-65°F to 300°F (-54°C to 149°C)	NA	680 psi [5 N/mm²]*
<b>AA 3494™</b>	234138	1 liter	Transparent liquid	Ultraviolet (UV)/ visible light	Glass	6,000	-65°F to 300°F (-54°C to 149°C)	D 65	680 psi [5 N/mm²]*
<b>AA 3922™</b>	312057	25 ml	Transparent to hazy liquid	Ultraviolet (UV)/ visible light	Stainless steel	300	-65°F to 300°F (-54°C to 149°C)	D 66	3400 psi [23 N/mm²]
	312054	1 liter							
<b>AA 3951™</b>	2298393	25 ml	Transparent, colorless to straw colored liquid	Ultraviolet (UV)/ visible light	Plasticized PVC, TPEs, thermoset rubbers, polycarbonate, ABS, Acrylic, HDPE, PP	150	-65°F to 212°F (-54°C to 100°C)	NA	3200 psi [22 N/mm²]
	2298394	1 liter							
<b>AA 3953™</b>	2298717	25 ml	Transparent, colorless to straw colored liquid	Ultraviolet (UV)/ visible light	Plasticized PVC, TPEs, thermoset rubbers, polycarbonate, ABS, Acrylic, HDPE, PP	550	-65°F to 212°F (-54°C to 100°C)	NA	3200 psi [22 N/mm²]
	2298718	1 liter							
<b>AA 3961™</b>	2464890	25 ml	Transparent, colorless to straw colored liquid	Ultraviolet (UV)/ visible light	metals, plastics, stainless steel, polycarbonate, ABS, Acrylic, HDPE, PP	80	-65°F to 300°F (-54°C to 149°C)	NA	3000 psi [21 N/mm²]
	2464891	1 liter							
<b>AA 3963™</b>	2483476	25 ml	Transparent, colorless to straw colored liquid	Ultraviolet (UV)/ visible light	metals, plastics, stainless steel, polycarbonate, ABS, Acrylic, HDPE, PP	350	-65°F to 300°F (-54°C to 149°C)	NA	3400 psi [23 N/mm²]
	2483477	1 liter							
<b>OPAQUE SUBSTRATES - ABILITY TO CURE IN AREAS SHADOWED FROM LIGHT</b>									
<b>4310™</b>	1401792	1 oz	Transparent, light yellow-green to dark blue-green liquid	Dual Cure [Ultraviolet (UV)/visible light]	Plastics, Rubbers. Metals	175	-65°F to 300°F (-54°C to 149°C)	D 84	1300 psi [9 N/mm²]
	1401790	1 lb							
<b>4311™</b>	1401791	1 oz	Transparent, light yellow-green to dark blue-green liquid	Dual Cure [Ultraviolet (UV)/visible light]	Plastics, Rubbers. Metals	1,050	-65°F to 200°F (-54°C to 93°C)	D 84	3200 psi [22 N/mm²]
	1401789	1 lb							
<b>AA 352™</b>	135413	50 ml	Transparent light amber liquid	Ultraviolet (UV) light & Activator Cure	Metal and glass	20,500	-65°F to 300°F (-54°C to 149°C)	D 60	1200 psi [8 N/mm²]*
	135412	25 ml							
<b>SI 5031™</b>	693986	300 ml	Light yellow, translucent liquid	Ultraviolet (UV)/ visible light & Moisture	Plastics, Rubbers. Metals	5,500	-65°F to 400°F (-54°C to 200°C)	A 34	0.1 psi [10 N/mm²]**
<b>SI 5039™</b>	742348	300 ml	Light yellow, translucent paste	Ultraviolet (UV)/ visible light & Moisture	Plastics, Rubbers. Metals	220 g/min	-65°F to 350°F (-54°C to 180°C)	A 34	345 psi [2.4 N/mm²]**

\*PC to Glass

\*\*PC to PC Lap Shear



# Light Cure Bonding Process Improves Product Quality and Output.



“LOCTITE’s Engineering Solutions Expert helped us design a new production process that met all of our requirements and improved our quality and output.”

An ink cartridge remanufacturer was having trouble finding a product that passed their adhesion and pressure test requirements. They had previously tested another adhesive alternative but it had poor bond strength to ABS and failed pull tests. The solution: LOCTITE® 4311™ Light Cure Adhesive, which dispenses precisely and cures quickly, and LOCTITE® 770™ Primer. With the help of a LOCTITE® Engineering Solutions

Expert, the team redesigned their assembly process by brushing LOCTITE® 770™ Primer onto the ABS part, then dispensing LOCTITE® 4311™ onto the bond area using the existing LOCTITE 200D Benchtop Robot and curing it with exposure to the LOCTITE® 4311™ light source for several seconds. The new process bonded well, passed repeated pull tests and improved ink cartridge quality and production output.

## BENEFITS

LOCTITE® 4311™ Light Cure Adhesive:

- Cures completely in several seconds beneath the LOCTITE 7411 UV™ Flood System
- Meets all manufacturing requirements without additional capital investment

LOCTITE® 770™ Primer:

- Increases the bond strength of LOCTITE 4311™ to pass all strength requirements

# CLEANERS

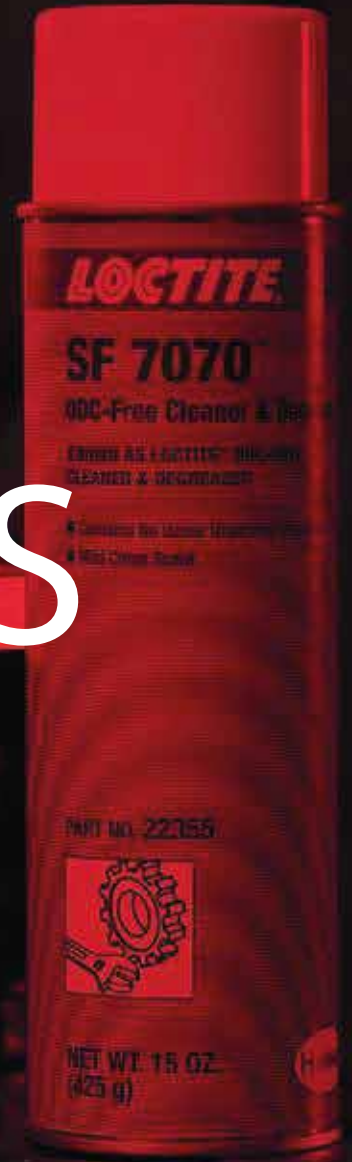

Over 60 years of  
experience with cleaners  
and degreasers.

For safe, effective  
cleaning.

PROBLEM

Without cleaners and degreasers: Contaminants, soils and oils on components cause performance failures in production and plant operations.

SOLUTION

With cleaners and degreasers: Cleaner components increase production quality, help to decrease operating costs, and maximize performance of LOCTITE Adhesives.

# Clean parts, hands and mechanical equipment

LOCTITE® cleaners and degreasers provide highly effective water- and solvent-based cleaning of components, worktops, floors, parts and hands. The major factors to consider are drying time, residue, odor and substrate compatibility.

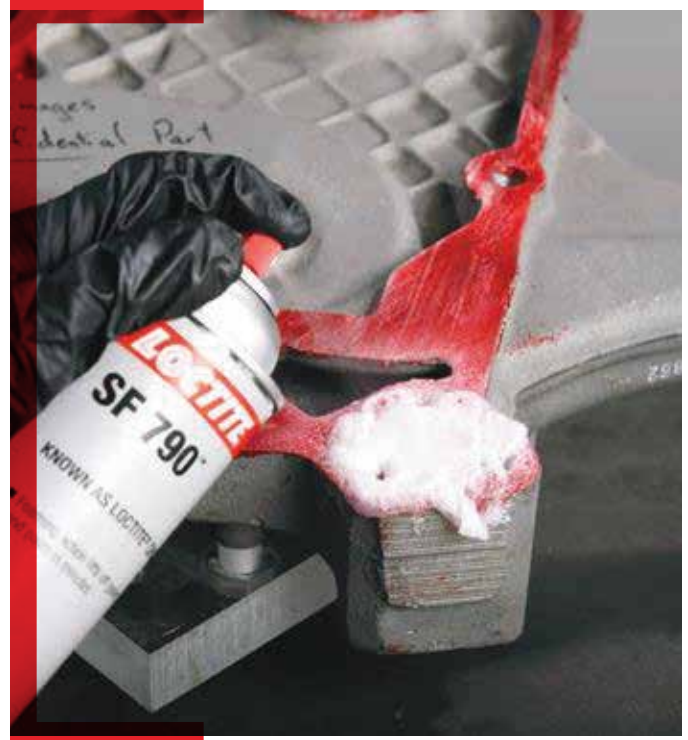

## How to choose the right cleaner.

### DEGREASING/PARTS CLEANING

For removing dirt, resins, metal filings, lacquer, oils and greases from components.

### HAND CLEANING

Available with and without abrasives for removing dirt, grease, grime, oil and adhesives from hands.



BEST SELLER

## SF 790™

Cleaner

LOCTITE SF 790™ is a grey to off-white methylene chloride liquid solvent in an aerosol spray designed to remove baked-on chemical gaskets, gasket cements and conventional gasket materials from metal surfaces. It works by removing pre-cut conventional gasket cements and formed-in-place chemical gaskets. Its aerosol spray form enables spray application onto intricate shapes with maximum penetration.



BEST SELLER

## SF 7070™ Cleaner

ODC-Free Cleaner/Degreaser

LOCTITE SF 7070 is a solvent-based parts cleaner and degreaser formulated specifically to prepare plastic components ready for bonding with adhesives. Suitable for use as a spray or in immersion cleaning at room temperature, the product is able to remove most oils, greases, lubrication fluids, metal cuttings and fines from plastic parts without the risk of stress cracks.



Find the right  
product for  
your application



## Degreasers / Parts Cleaners

LOCTITE ® **SF 7070**™  
LOCTITE ® **SF 7840**™  
LOCTITE ® **SF 7611**™  
LOCTITE ® **SF 790**™  
LOCTITE ® **SF 768**™

## Hand Cleaners

LOCTITE ® **SF 7617**™

SEE OUR FULL LINE OF  
CLEANING PRODUCTS:  
[cleaners.loctite.us](http://cleaners.loctite.us)

## Degreasers & Parts Cleaners



**SF 7070**™  
ODC-Free

A non-aqueous, hydrocarbon-based solvent designed for cleaning and degreasing surfaces to be bonded with adhesives, as well as for general-purpose industrial cleaning. Safe on aluminum, rubber and most plastics, and will not cause flash rusting on water-sensitive parts. Dries residue-free.



**SF 7611**™  
Fast Drying

Industrial strength, solvent-based aerosol cleaner designed to penetrate, dissolve and remove contaminants from all types of metal assemblies. Evaporates quickly and leaves no residue.



**SF 7840**™  
Water-based

Concentrated, biodegradable, general purpose parts cleaner and degreaser that is solvent-free, non-toxic and non-flammable. Can be diluted with water.



**SF 790**™  
Parts Cleaner

A gray to off-white methylene chloride liquid solvent in an aerosol spray designed to remove baked-on chemical gaskets, gasket cements and conventional gasket materials from metal surfaces. Its aerosol spray form enables spray application on to intricate shapes with maximum penetration.



**SF 768**™  
Clean-Up Solvent

A solvent blend designed to remove cured cyanoacrylate/instant adhesive or debond parts assembled with instant adhesive. Can also be used for cleanup of dispensing equipment.

## Hand Cleaners



**SF 7617**™  
Wipes

Citrus-scented hand cleaning towels with a cleaning formula that is capable of removing tar, grease, wax, ink, paint, lubricants and adhesives.

## CLEANERS

Product	IDH Number	Package Size	Drying Time	Residue/Rinsability	Odor
<b>DEGREASERS</b>					
<b>SF 7070™</b>	231562	15 oz.	Equivalent to the evaporation rate of water. Wiping or blowers will accelerate dry time.	No rinse and no residue	Mild citrus
<b>SF 7611™</b>	234941	19 oz.	1 to 5 minutes	No rinse and no residue	Mild solvent
<b>PART CLEANERS</b>					
<b>SF 7840™</b>	2046047	1 gallon	Equivalent to the evaporation rate of water. Wiping or blowers will accelerate dry time.	Rinses residue-free with water	Cherry scent
	2046048	5 gallon			
<b>SF 768™</b>	235018	1.75 fl. oz.	< 30 seconds	No rinse and no residue	Solvent
<b>SF 790™</b>	135544	18 oz.	Leave on surface for 5 to 10 minutes. Wipe/scrape clean.	Oily residue	Solvent
<b>HAND CLEANER</b>					
<b>SF 7617™</b>	337637	75 count	1 to 5 minutes	No rinse and no residue	Powerful citrus





# WEAR PREVENTION

# Fight abrasion, erosion, corrosion, chemical attack and wear.

## For longer, more efficient performance.

---



### PROBLEM

Without wear resistant coatings: Abrasion and corrosion can damage components.

### SOLUTION

With wear resistant coatings: Components are protected from direct process damage and equipment life is extended.

# Protect. Repair. Rebuild.

Wear prevention solutions provide a sacrificial coating on new or worn surfaces, to provide wear and impact resistance and extend the life of parts. LOCTITE® offers a range of wear prevention solutions for a range of applications.

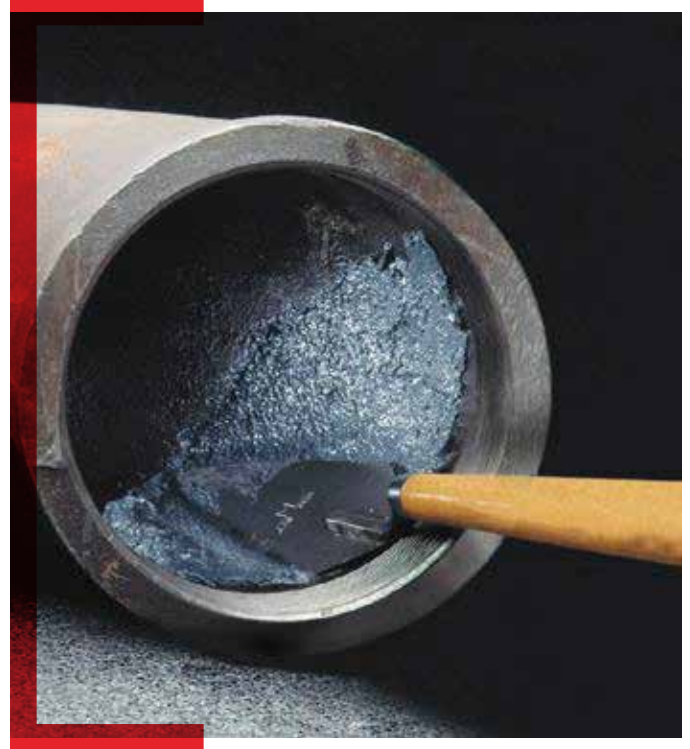

## How to choose the right wear prevention.



### PARTICLE ABRASION

Trowelable, brushable and sprayable solutions for fighting abrasion from particles ranging from small to large.



### FLUID EROSION

Coatings to combat the fine particles found in fluids on components such as a pump.



### CHEMICAL ATTACK

Advanced epoxy products to protect equipment from extreme chemical attack and corrosion.



BEST SELLER

## PC 7218™

### General Purpose

LOCTITE PC 7218™ is a 2-part, grey, ceramic-filled, trowelable, epoxy-based surface coating designed to protect parts from coarse particle abrasion or erosion on metals (with or without chemical attack). It is designed for parts such as cyclones/separator bodies, dust collectors/exhausters, pump liners/impellers, fan blades and housings, chutes/hoppers and elbows and transition points.

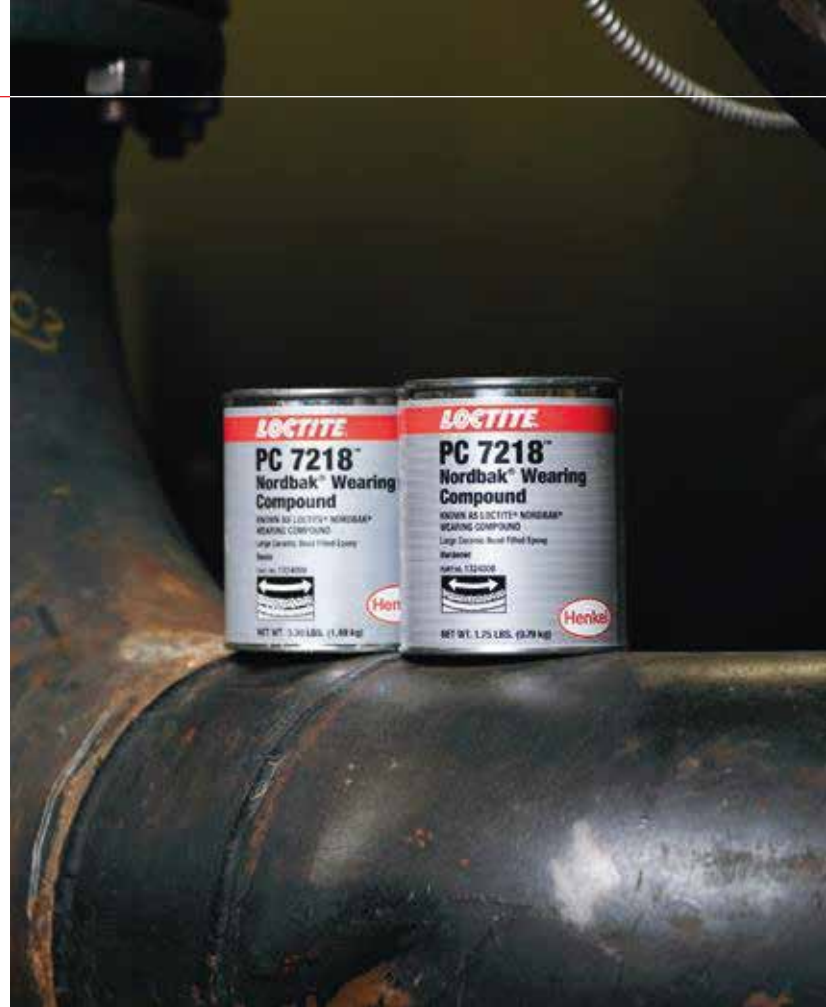

BEST SELLER

## PC 9313™

### Impact Resistance

LOCTITE PC 9313™ is a two-component, rubber modified epoxy that offers the wear resistance properties of an epoxy along with impact resistance not usually found in epoxy formulations. With impact resistance superior to ceramic tile. It is recommended for lining and protecting flumes, troughs, elbows, hoppers, discharge chutes, and other processing equipment that is exposed to both abrasion and impact under typical dry service temperatures of -20° to +250°F.



Find the right  
product for  
your application



### Particle Abrasion

LOCTITE<sup>®</sup> **PC 7218**<sup>™</sup>  
LOCTITE<sup>®</sup> **PC 9599**<sup>™</sup>  
LOCTITE<sup>®</sup> **PC 9313**<sup>™</sup>  
LOCTITE<sup>®</sup> **PC 7317**<sup>™</sup>  
LOCTITE<sup>®</sup> **PC 7383**<sup>™</sup>  
LOCTITE<sup>®</sup> **PC 7222**<sup>™</sup>

### Fluid Erosion

LOCTITE<sup>®</sup> **PC 7227**<sup>™</sup>  
LOCTITE<sup>®</sup> **PC 7255**<sup>™</sup>

### Chemical Attack

LOCTITE<sup>®</sup> **PC 7319**<sup>™</sup>  
LOCTITE<sup>®</sup> **PC 7266**<sup>™</sup>

## Particle Abrasion

WEAR PREVENTION



### PC 7218<sup>™</sup> General Purpose

Working Life: 30 minutes  
Cure Speed: 7 hours  
Temperature (max): 250°F  
Color: Thick Grey Paste



### PC 7222<sup>™</sup> Flexible

Working Life: 30 minutes  
Cure Speed: 5 hours  
Temperature (max): 220°F  
Color: Grey Paste



### PC 9313<sup>™</sup> Impact Resistant

Working Life: 30 minutes  
Cure Speed: 7 hours  
Temperature (max): 250°F  
Color: Grey



### PC 7317<sup>™</sup> Fine Particles < 1.5mm

Working Life: 30 minutes  
Cure Speed: 7 hours  
Temperature (max): 250°F  
Color: Grey



### PC 7383<sup>™</sup> Flexible

Working Life: 50 minutes  
Cure Speed: 24 hours  
Temperature (max): 176°F  
Color: Black



### PC 9599<sup>™</sup> Fast Cure

Working Life: 10-15 minutes  
Cure Speed: 3 hours  
Temperature (max): 220°F  
Color: Thixotropic Blue Paste

SEE THE FULL LINE OF  
WEAR PREVENTION AT:  
[wear-prevention.loctite.us](http://wear-prevention.loctite.us)

## Fluid Erosion

WEAR PREVENTION



**PC 7227™**  
Brushable

Working Life: 34 to 48 minutes  
Cure Speed: 24 hours  
Temperature (max): 200°F  
Color: Grey



**PC 7255™**  
Sprayable

Working Life: 40 to 70 minutes  
Cure Speed: 4 hours  
Temperature (max): 203°F  
Color: Brilliant Green

## Chemical Attack

WEAR PREVENTION



**PC 7319™**  
Brushable

Working Life: 28 to 40 minutes  
Cure Speed: 36 hours  
Temperature (max): 250°F  
Color: Grey Liquid



**PC 7266™**  
Sprayable

Working Life: 40 minutes  
Cure Speed: 4 hours  
Temperature (max): 250°F  
Color: Blue Liquid

WEAR PREVENTION											
Product	IDH Number	Package Size	Coverage	Color	Maximum Operating Temperature	Compressive Strength	Shore Hardness	Working Time [min.]	Functional Cure [hrs.] 77°F (25°C)	Mix Ratio by Volume	Mix Ratio by Weight
<b>PARTICLE ABRASION</b>											
<b>PC 7218™</b>	1234008	5 lb. kit	740 cm <sup>2</sup> @ 6 mm thick per 1 kg kit	Thick Grey Paste	250°F [120°C]	16,000 psi [110.3 N/mm <sup>2</sup> ]	90	30	7	2:1	2:1
	1323940	25 lb. kit									
<b>PC 7222™</b>	209827	3lb. kit	53 in <sup>2</sup> @ 0.25 in. thickness per 1 lb	Grey Paste	220°F [105°C]	10,360 psi [71.4 N/mm <sup>2</sup> ]	85	30	5	2:1	2:1
<b>PC 7317™</b>	209824	3lb. kit	740 cm <sup>2</sup> @ 6 mm thick per 1 kg kit	Grey	250°F [120°C]	15,000 psi [103.4 N/mm <sup>2</sup> ]	85	30	7	4:1	4:1
	209676	25 lb. kit									
<b>PC 7383™</b>	2395759	10 kg kit	0.63 m <sup>2</sup> @ 6 mm thick per 5 kg kit	Black	176°F [80°C]	NA	90	50	24	1:1	1:1
<b>PC 9313™</b>	1327836	25 lb. kit	0.8 m <sup>2</sup> @ 0.63 cm thick per 25lb	Grey	250°F [120°C]	12,000 psi [82.7 N/mm <sup>2</sup> ]	85	30	7	2:1	2:1
<b>PC 9599™</b>	235599	6 lb. kit	0.2 m <sup>2</sup> @ 6 mm thick per 2.5kg	Thixotropic blue paste	220°F [105°C]	12,150 psi [83.7 N/mm <sup>2</sup> ]	90	10 to 15	3	2:1	2:1
<b>FLUID EROSION</b>											
<b>PC 7227™</b>	209826	2 lb. kit	0.55 m <sup>2</sup> @ 1 mm thick per 0.9kg	Grey	200°F [93°C]	12,500 psi [86.1 N/mm <sup>2</sup> ]	85	34 to 48	24	2.75:1	4.8:1
<b>PC 7255™</b>	2012143	900 ml	2.7 m <sup>2</sup> @ 0.25 mm thick per kg	Brilliant green	203°F [95°C]	15,400 psi [106.1 N/mm <sup>2</sup> ]	86	40 to 70	4	100:50	100:50
<b>CHEMICAL ATTACK</b>											
<b>PC 7266™</b>	2082026	1 kg kit	8.2 m <sup>2</sup> @ 100 micron per kg	Brilliant blue liquid	N/A	16,000 psi [110.3 N/mm <sup>2</sup> ]	83	40	4	N/A	100:22
<b>PC 7319™</b>	209816	11 lb. kit	6.8 m <sup>2</sup> @ 0.5 mm thick per 5.5 kg	Grey liquid	250°F [120°C]	9,840 psi [67.8 N/mm <sup>2</sup> ]	85	28 to 40	36	2.3:1	3.4:1

LOCTITE SERVICES

PROTECT COMPONENTS  
AND EXTEND  
OPERATIONAL LIFE.

services.loctite.us



# Coating against fluid erosion.



Thanks to a LOCTITE® Engineering Solutions Expert, reliability and performance has been improved.

An industrial pump repair shop needed to improve reliability and performance for a customer's municipal wastewater pumps, which were failing prematurely due to erosion and cavitation. During an on-site consultation, a LOCTITE Technical Sales Engineer suggested LOCTITE® EA 3478™ Superior Metal and LOCTITE® PC 7255™ Sprayable Ceramic to repair damage and protect the wetted components against the harsh conditions. The LOCTITE Technical Sales Engineer guided the team on how to properly prepare the surface, to ensure

maximum adhesion and longevity. To fill large gaps in the pump caused by cavitation and erosion, LOCTITE® EA 3478™ Superior Metal was used to rebuild the pump geometry, followed by the application of LOCTITE® PC 7255™ Sprayable Ceramic to coat and protect all wetted components in the pump. Once back in service, the pump's mean time between failures was greatly increased, allowing for more reliable operation and maintenance schedules.

## BENEFITS

LOCTITE® EA 3478™ Superior Metal and LOCTITE® PC 7255™ Sprayable Ceramic

- Fills large gaps caused by cavitation and erosion.
- Coats and protects wetted components.
- Increases mean time between failure.
- Allows for more regular operation and maintenance schedules



# REBUILDING

# Repair shafts and other steel, aluminum or rubber components.

## For longer life and better chemical resistance.

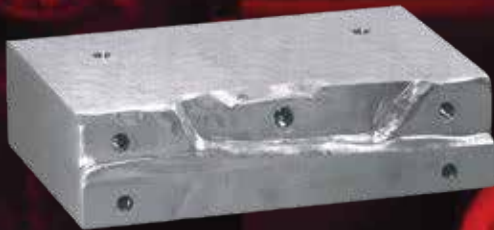

### PROBLEM

Without rebuilding: Damaged components reduce process efficiency, add excess stress to equipment, increase safety hazards and most importantly, add costs.



### SOLUTION

With rebuilding: Equipment is repaired quickly on-site, component integrity and seals are restored, process efficiencies are enhanced, and costs are minimized through part and component salvage.

# Rebuilding damaged parts.

Rebuilding solutions can be used to repair rubber, steel, aluminum and other metal components. Metal rebuilding solutions offer high compressive strength and can be machined, drilled or tapped after cure. Rubber repair solutions offer excellent abrasion resistance and outstanding adhesion to metal and rubber.



## How to choose a rebuilding product.

Choose a rebuild product based on substrate type and form of solution desired. LOCTITE offers a range of rebuilding solutions from kneadable to flowable.



DAMAGED METAL PART

Trowelable or kneadable solutions for repairing, restoring or rebuilding damaged metal machinery, equipment and parts without the need for heat or welding.



DAMAGED RUBBER PART

Durable, tough and flexible repairs of conveyor belts and other damaged rubber equipment and parts, quickly and easily.



BEST SELLER

## EA 3478™

High Performance

LOCTITE® EA 3478™ is a 2-part, ferro-silicon filled epoxy resin system. It is extremely resistant to corrosion, chemical attack and abrasion. Helps to restore tolerances to worn shafts, repairing worn keyways and damaged housings, filling pitted surfaces in worn machinery and restoring fit to bearing housings.

 Working Time: 20 minutes

 Cure Speed: 4 hours



BEST SELLER

## PC 7350™

Rubber Repair

A premium rubber repair compound designed for conveyors and other rubber parts. Offers excellent abrasion resistance and outstanding adhesion to metal and rubber.

 Working Time: 7 minutes

 Cure Speed: 2 hours



Find the right product for your application



 Damaged Metal Parts

LOCTITE® EA 3463™  
LOCTITE® EA 3478™

 Damaged Rubber Parts

LOCTITE® PC 7350™  
LOCTITE® PC 7393™

## Damaged Metal Parts



EA 3463™ Repair  
Epoxy Stick  
Fast Repair

 Working Time: 3 minutes

 Cure Speed: 10 minutes

Substrate: Metal  
Form: Kneadable Putty



EA 3478™  
Superior Metal  
High Performance

 Working Time: 20 minutes

 Cure Speed: 4 Hours

Substrate: Metal  
Form: Trowelable

## Damaged Rubber Parts



PC 7350™  
Conveyor Belt  
Repair  
Self-Leveling

 Working Time: 7 minutes

 Cure Speed: 2 Hours

Substrate: Rubber  
Form: Self-Leveling



PC 7393™ Rapid  
Rubber Repair  
Fast repair

 Working Time: 1 minute

 Cure Speed: 2 Hours

Substrate: Rubber  
Form: Spreadable

SEE THE FULL  
PORTFOLIO OF  
REBUILDING AT:  
[rebuilding-material.loctite.us](http://rebuilding-material.loctite.us)

## BELT REPAIR

Product	IDH Number	Package Size	Coverage	Color	Tensile Strength	% Elongation	Shore A Hardness	Working Time (min.)	Functional Cure [hrs.] 77°F / 25°C
---------	------------	--------------	----------	-------	------------------	--------------	------------------	---------------------	---------------------------------------

### RUBBER REPAIR

<b>PC 7350™</b>	2073202	400 ml	567 cm² for 6 mm thickness	Mixed: Black	1600 psi [11 N/mm²]	275	87	7	2
<b>PC 7393™</b>	428557	400 ml	567 cm² for 6 mm thickness	Mixed: Black	N/A	N/A	86	1	2

## REBUILD EXPOXIES

Product	IDH Number	Package Size	Coverage	Color	Compressive Strength [psi]	Tensile Strength [psi]	Shore Hardness	Working Time	Functional Cure [hrs.] 77°F / 25°C
---------	------------	--------------	----------	-------	----------------------------	------------------------	----------------	--------------	---------------------------------------

### STICK

<b>EA 3463™</b>	209681	4 oz.	10 cm² for 6 mm thickness	Metallic Black	7200*	2730 psi [18 N/mm²]	≥70 ISO 868, Shore D	2.5 to 5	10 min.
-----------------	--------	-------	---------------------------	----------------	-------	------------------------	-------------------------	----------	---------

### TROWELABLE

<b>EA 3478™</b>	209822	1 lb. kit	323 cm² for 6 mm thickness	Mixed: Grey	19000*	3900	86 ISO 868, Durometer D	20	4 hrs.
-----------------	--------	-----------	----------------------------	-------------	--------	------	----------------------------	----	--------

\* Different ISO tests used

LOCTITE SERVICES

RESTORE COMPONENT  
INTEGRITY.

services.loctite.us

LOCTITE® EA 3478™, PC 7227™, SF 7611™



# Restoring Worn Metal to its Near-original Dimensions.



“We went from replacing 2 impellers a year to almost never replacing impellers, thanks to LOCTITE®.”

A water treatment plant with 25 mixer impellers was searching for a way to avoid the high cost of OEM replacement parts. The plant was replacing at least 2 impellers each year at a cost of \$6,000 per unit, plus the cost of renting a crane to remove the impellers. They had tried competitive wear resistant coatings previously, but they failed after only a few months of use. LOCTITE® EA 3478™ Superior Metal and LOCTITE® PC 7227™ Brushable Ceramic were an ideal solution for restoring the impellers. After the impellers were removed from service and grit blasted to leave

a bare metal surface, a LOCTITE Engineering Solutions Expert showed the team how to first clean with LOCTITE® SF 7611™ Pro Strength Parts Cleaner to remove any oil or grease residues and apply LOCTITE® EA 3478™ Superior Metal to restore eroded surfaces to a near-original surface dimension, grinding the cured product as needed to optimize impeller efficiency. Finally, a primary coat of LOCTITE® PC 7227™ Brushable Ceramic blue was applied, followed by a top coat of the same material in gray. As the gray coating wears away and the blue shows through,

re-coating during the next downtime can be scheduled. The result: the plant has eliminated almost all impeller replacement costs while reducing downtime expenses substantially.

## BENEFITS

LOCTITE® EA 3478™ Superior Metal:

- Restores impeller original dimensions to improve pumping efficiency.

LOCTITE® PC 7227™ Brushable Ceramic:

- Protects metal from abrasion to prolong impeller service life.

A red oil dropper is shown in the upper right corner, with a single drop of oil falling from its tip. The drop is captured mid-fall, creating a blurred, elongated shape as it descends. The background is a dark, textured surface, possibly a metal or stone, which is illuminated by a soft red glow from the dropper. The overall scene is set against a dark, almost black background, emphasizing the vibrant red of the dropper and the falling oil.

# LUBRICANTS

# Long-lasting lubrication. For longer component life and performance.

---



## PROBLEM

Without lubricants:  
Moving parts can  
corrode and seize.

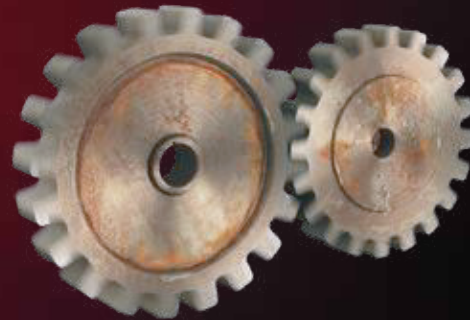

## SOLUTION

With lubricants:  
Assemblies maintain  
performance longer.

# Keep moving parts moving.

Lubricants can be used for everything from releasing seized parts to providing long-lasting lubrication of moving parts. LOCTITE® offers lubricants that can address and protect against a wide range of temperature, pressure and thermal stability needs.

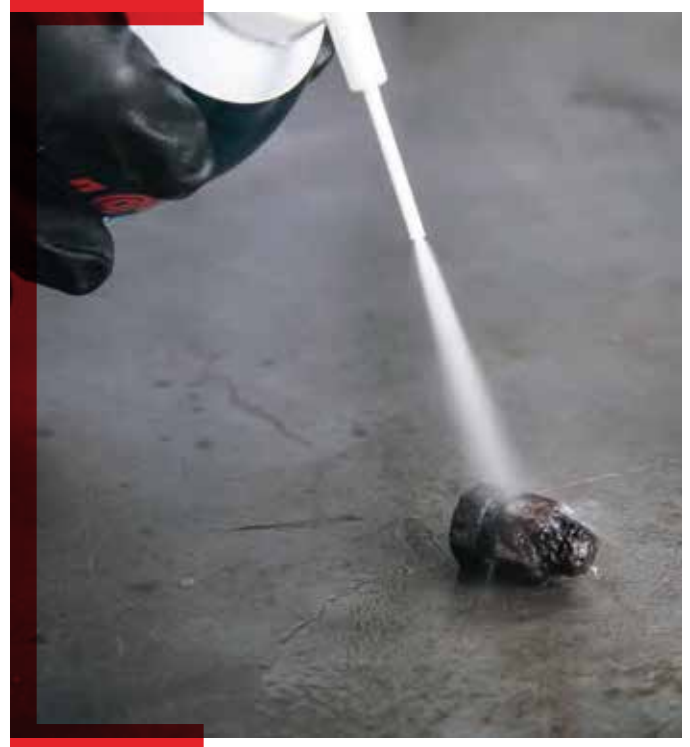

SEE THE FULL PORTFOLIO OF LUBRICANTS AT:  
[lubricants.loctite.us](https://lubricants.loctite.us)



BEST SELLER

## LB 8034™

Synthetic Grease

IDH 457456 – 3 oz.

LOCTITE LB 8034 is a high-performance synthetic grease that provides long life protection for equipment exposed to a wide range of temperature, pressure and cycle times. Use as a lubricant and protective anti-rust film on bearings and machine parts, or as a release agent on gaskets and seals.



Temperature Resistance: -40°F to 500°F



Base Oil: PAO



BEST SELLER

## LB 8040™

Seized, Rusted Parts

IDH 2343777 – 400 ml.

LOCTITE LB 8040™ is the solution for releasing seized or corroded parts. Instantly freezes seized and rusted parts (bolts, nuts, studs) down to -38°F. The shock-freeze causes microscopic cracks in the layer of rust, allowing the lubricating ingredient to wick directly into the rust. Dismantles parts in 1-2 minutes.



Temperature Resistance: -4°F to 113°F



Base Oil: Mineral oils, Silicone-free



BEST SELLER

## LB 8421™

Gear, Chain and Cable Lubricant

IDH 1906177 – 12 oz.

LOCTITE LB 8421 is a solvent-based, oily lubricant spray that foams up when applied, protecting and prolonging the life of parts exposed to harmful or corrosive elements. The foaming action permits fast, deep penetration with reduced run-off. Typically used on equipment with gears, chains, cable and wire rope.



Temperature Resistance: 250°F



Base Oil: Hydrocarbon





# ANTI-SEIZE PRODUCTS

# Prevent seizing. Even in extreme environments.

---



## PROBLEM

Without anti-seize lubricants: Parts seize at extreme temperatures or in corrosive environments.



## SOLUTION

With anti-seize lubricants: Assemblies maintain operation in all types of extreme conditions with more reliable removal and on-torque performance.

# Keep assemblies from seizing.

Anti-seize lubricants are used in harsh environments to keep assemblies from seizing. They also protect against rust, corrosion and galling even in extreme temperature conditions. Temperature is a key consideration when choosing a LOCTITE® anti-seize lubricant, along with substrate material and contamination restrictions.

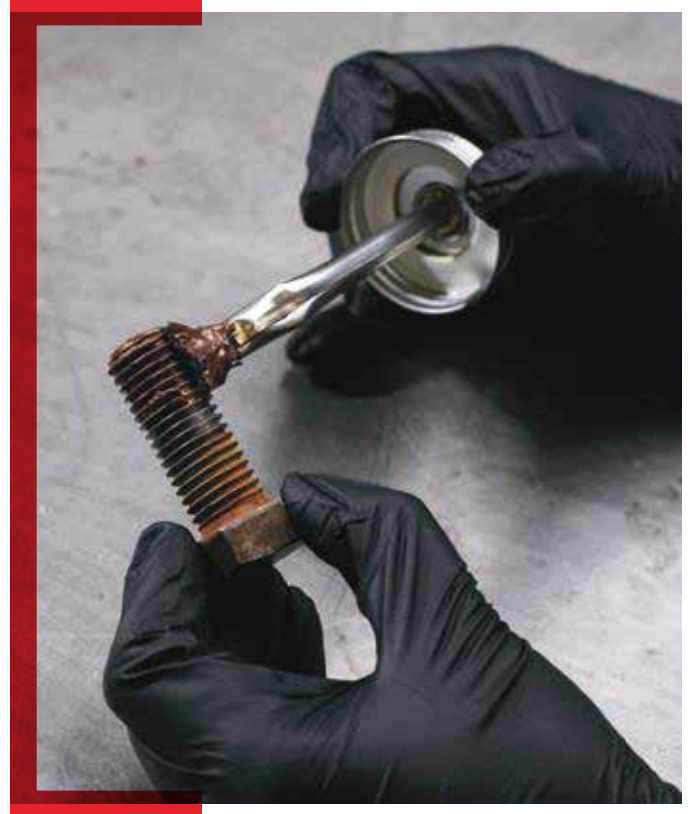

## How to choose the right anti-seize product.



### TEMPERATURE

LOCTITE® anti-seize lubricants are designed to protect your equipment from a wide range of temperatures, which allows for a wide range of applications. To choose the right anti-seize lubricant, choose the conditions in which your equipment operates, from -20°F to 2400°F.



### METAL FREE

LOCTITE® METAL-FREE FORMULATIONS – A growing concern for all types of industries is the dispersal of “heavy” metals like lead, nickel, zinc and others, into the environment. Metal-free formulations offer the same performance as traditional products without heavy metals.



BEST SELLER

# LB 8008™

Copper-based

Exclusive formula suspends copper and graphite in a high quality grease. Protects metal parts from rust, corrosion, galling and seizing at temperatures to 1800°F.

Temperature Resistance: 1800°F

Metal Free: No



BEST SELLER

# LB 771™

Nickel-based

Copper-free. Recommended for stainless steel and other metal fittings. For preventing corrosion, seizing and galling in harsh chemical environments and temperatures to 2400°F.

Temperature Resistance: 2400°F

Metal Free: No

Find the right product for your application



**Up to 1600° F**

LOCTITE® **LB 8150™**

**Up to 1800° F**

LOCTITE® **LB 8008™**

**Up to 2400° F**

LOCTITE® **LB 771™**

LOCTITE® **LB 8809™**

LOCTITE® **LB 8023™**

SEE THE FULL LINE OF OUR ANTI-SEIZE PRODUCTS AT:  
[antiseize.loctite.us](http://antiseize.loctite.us)

**Up to 1600° F**

ANTI-SEIZE PRODUCTS



**LOCTITE LB 8150™**  
Silver



Temperature Range:  
-20°F to 1600°F



Metal Free: No

Color: Silver  
Solid Lubricating Agent: Graphite/  
Aluminum

**Up to 1800° F**

ANTI-SEIZE PRODUCTS



**LOCTITE LB 8008™**  
Copper



Temperature Range:  
-20°F to 1800°F



Metal Free: No

Color: Copper  
Solid Lubricating Agent: Copper/  
Graphite

**Up to 2400° F**

ANTI-SEIZE PRODUCTS



**LOCTITE LB 771™**  
Nickel



Temperature Range:  
-20°F to 2400°F



Metal Free: No

Color: Silver  
Solid Lubricating Agent: Nickel/Graphite



**LOCTITE LB 8809™**  
High Performance/  
Heavy Duty



Temperature Range:  
-20°F to 2400°F



Metal Free: Yes

Color: Grey  
Solid Lubricating Agent: Graphite/  
Calcium Fluoride



**LOCTITE LB 8023™**  
Water Wash-out Resistance



Temperature Range:  
-20°F to 2400°F



Metal Free: Yes

Color: Black  
Solid Lubricating Agent: Calcium  
Sulfonate

## ANTI-SEIZE PRODUCTS

Product	IDH Number	Package Size	Temperature Resistance	Color	Torque Coefficient*	Metal-Free
UP TO 1600°F (870°C)						
<b>LB 8150™</b>	199012	8 oz. brushtop can	1600°F (870°C)	Silver	0.18	No
	235005	1 lb. brushtop bottle				
UP TO 1800°F (980°C)						
<b>LB 8008™</b>	234263	8 oz. brushtop bottle	1800°F (980°C)	Copper	0.16	No
	160796	1 lb. brushtop bottle				
	233317	1 lb. brushtop metal can				
	234202	1 lb. can				
UP TO 2400°F (1315°C)						
<b>LB 771™</b>	235028	8 oz. brushtop bottle	2400°F (1315°C)	Silver	0.13	No
	135543	1 lb. brushtop bottle				
	234248	1 lb. can				
<b>LB 8009™</b>	234347	9 oz. brushtop bottle	2400°F (1315°C)	Grey	0.16	Yes
	209758	18 oz. brushtop bottle				
<b>LB 8023™</b>	299175	8 oz. brushtop bottle	2400°F (1315°C)	Black	0.16	Yes
	275026	1 lb. brushtop bottle				

\* K value on steel nuts and bolts.





# SPECIALTY MAINTENANCE TECHNOLOGIES



Solutions for  
any situation.  
Even  
unexpected  
ones.

# For a wide range of specialized maintenance and repair scenarios.

With deep expertise in industrial maintenance and repair, LOCTITE has been able to develop a wide range of technologies suitable for solving nearly situation.

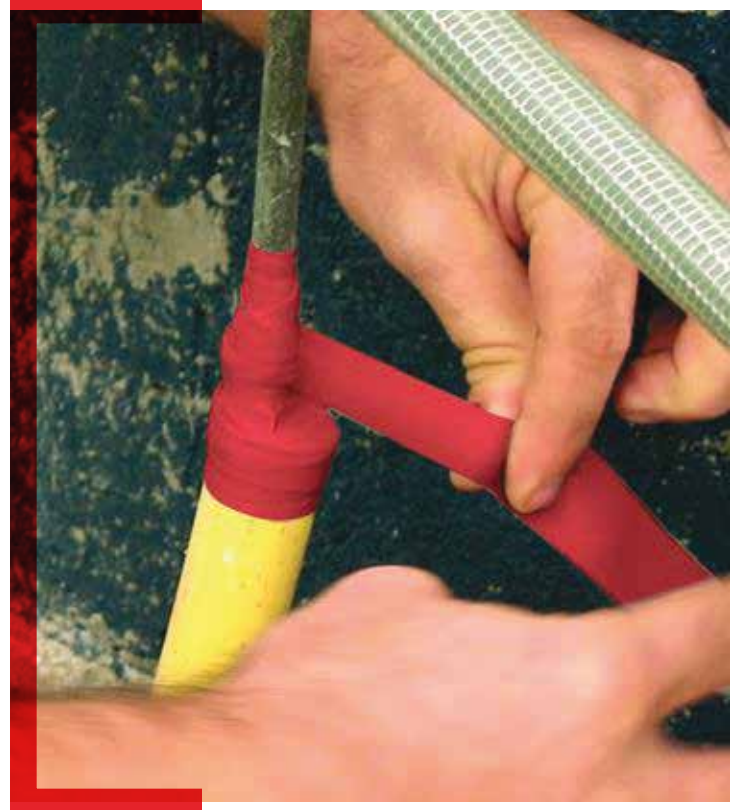

#### PIPE REPAIR SYSTEM

Composite repair system to repair and protect metal pipes.

#### GROUTING & CONCRETE REPAIR

Self-leveling, non-shrinking grouting that is stronger than concrete, and chemical and corrosion resistant.

#### RUST PREVENTION & CONVERSION

Stabilizes existing rust, guards against corrosion, prevents electrochemical corrosion and provides protection against flash rust.

#### WELDING PROTECTION

Protects welding equipment against metal spatter for 8 hours without reapplication.

#### INSULATING & SEALING

Self-fusing silicone wrap for electrical insulation and sealing applications even for pipes under pressure.

#### O-RING SEALS REPLACEMENT OR REPAIR

Eliminates the need to inventory different sized O-rings, creating strong joints that resist water and oil.

#### TOOL KITS

Compact kits containing an assortment of technologies to solve the most common mechanical failures.

#### REPAIR ADHESIVES

To meet tough, on-the-job, requirements, LOCTITE specialty repair adhesives provide a combination of cure speed, strength and environmental resistance to get the job done.



BEST SELLER

## PC 7210™ /PC 5085™

### Pipe Repair System

LOCTITE® PC 7210™ is a light orange, 2-part, room temperature-cure, toughened epoxy resin paste. It is used in combination with LOCTITE PC 5085™, a glass-carbon fiber tape, as a composite repair system to repair and protect metal pipes and tanks in the petroleum, petrochemical and natural gas industries. It can be used where high strength, corrosion protection and chemical resistance is required.



BEST SELLER

## PC 9410™

### Magna-Crete Concrete Repair

LOCTITE® PC 9410™ is a 2-part, rapid setting, liquid magnesium phosphate-based concrete repair and grouting system that outperforms conventional concrete repairs. This product is typically used wherever concrete is used in the construction and roads industries and in applications with an operating range of -58°F to 2012°F. This repair system can be applied at virtually any temperature without shrinkage and it is freeze/thaw and de-icing salt resistant. It bonds to new and old concrete as well as most construction materials including wood and steel.



## Find the right product for your application



### Pipe Repair System

LOCTITE® PC 7210™  
LOCTITE® PC 5085™

### Grouting & Concrete Repair

LOCTITE® PC 9626™  
LOCTITE® PC 9410™

### Insulating & Sealing

LOCTITE® SI 5075™

### Rust Prevention & Conversion

LOCTITE® SF 7515™  
LOCTITE® SF 754™ / SF 7625™

### Welding Protection

LOCTITE® SF 7900™

### Construction Adhesive

LOCTITE® PowerGrab Adhesive

### Spray Adhesive

LOCTITE® MR 5426™

### Replace or Repair O-Ring Seals

LOCTITE® O-Ring Making Kit

### Tool Kits

LOCTITE® Quick Service Toolkit  
LOCTITE® Toolbox

## Pipe Repair System

The pipe repair system of LOCTITE PC 7210™ and LOCTITE PC 5085™ is certified according to ISO TS 24817. Used where high strength reinforcement, corrosion protection and chemical resistance is required.



**PC 7210™**  
Toughened Epoxy  
IDH 2079209

Toughened epoxy resin paste used in combination with LOCTITE PC 5085™, a glass-carbon fiber tape, as a composite repair system. It can be used where high strength, corrosion protection and chemical resistance is required.



**PC 5085™**  
Glass-carbon Fiber Tape  
IDH 2081663

Composite fabric used in combination with resins, as a composite repair system to repair and protect metal pipes where high strength, corrosion protection or chemical resistance is required.

## Grouting & Concrete Repair



**PC 9626™**  
Deep Pour Grout  
IDH 235637

Aggregate-filled epoxy system for pours up to 6 in. deep, including self-leveling applications under rails and soleplates. High-strength material bonds to steel, concrete and itself. Withstands high-torque load.



**PC 9410™**  
Magna-Crete Concrete Repair  
IDH 235573

Two-component magnesium phosphate cement that sets rapidly and has a very high early strength. Ideal for road and aircraft runway repairs. It bonds to new and old concrete, as well as most construction materials including wood, glass and steel.

## Insulating & Sealing



**SI 5075™**  
Silicone Wrap  
IDH 1540599

Innovative self-fusing silicone wrap, perfect for electrical insulation and sealing applications even for pipes under pressure. It withstands extreme conditions such as salt water, fuel and acid fluids exposure.

## Rust Prevention & Conversion



**SF 7515**™  
Rust Prevention  
IDH 2081665

Amber, water-based, liquid surface treatment that delivers 48-hour protection against flash rust on large surfaces. Straightforward spray and wipe application.



**SF 754**™ / **SF 7625**™  
Rust Converter  
IDH 234981 / 2344218

Converts existing rust (rust required) into a stable base. Cured product acts as a primer ready for painting with oil or solvent-based paint. Protects surface from corrosion. Use on metal pipes, valves, fittings, outside surfaces of storage tanks, fences, guardrails, wrought iron furniture, conveyors, and construction and agricultural equipment.

## Replace or Repair O-Ring Seals



**O-Ring Making Kit**  
IDH 228171

Eliminates the need for an inventory of different sized O-rings. Joints resist water and oil and are as strong as the rubber itself.

## Welding Protection



**SF 7900**™  
Ceramishield  
IDH 1616692

Innovative ceramic coating that protects welding equipment against metal spatter for eight hours without reapplication. Minimizes equipment cleaning and eliminates downtime, reducing cost and enhancing productivity.

## Construction Adhesive



**PowerGrab**® Adhesive  
Industrial Grade  
IDH 2137678

A single-component, off-white, heavy duty, high strength, construction grade adhesive for interior and exterior repairs or building projects.

## Tool Kits



**LOCTITE**® Quick Service Toolkit  
IDH 302892

This compact kit contains everything needed to solve the most common mechanical failures.

## Spray Adhesive



**MR 5426**™  
Maximum Strength  
IDH 476035

A high-strength, high temperature (up to 170°F/77°C) spray adhesive designed for bonding foam, carpet, fabrics, plastics, rubber, etc. This is due to the high strength and temperature resistance of the product. It's resistant to extreme seasonal temperatures, is water resistant and dries clear.







**LOCTITE**® Toolbox  
IDH 618144







Containing the best LOCTITE technologies to solve some of the most common mechanical problems, this kit has everything a professional needs to increase reliability at the base component level.

## STRUCTURAL BONDING

## EPOXIES / POLYURETHANES

Product Image	IDH Number	Cartridge Size	Packagge Qty.	Description
	720225	50 ml	10	50 ml Mix Nozzle, Luer Tip, 6.0" overall length, 6.35 mm inner diameter, 21 elements; 1:1, 2:1, 4:1 mix ratios.
	720230	50 ml	10	50 ml Mix Nozzle, Stepped Tip; 6.0 mm overall length, 6.3 mm inner diameter, 21 elements; 1:1, 2:1, 4:1 mix ratios.
	720173	400 ml	10	200/400 ml Mix Nozzle, Stepped Tip, 7.3" overall length, 6.3 mm inner diameter, 24 elements; 1:1, 2:1 mix ratios.
	720174	400 ml	10	200/400 ml Round Mix Nozzle, Stepped Tip, 8.8 inch overall length, 8 mm inner diameter, 24 elements; 1:1, 2:1 mix ratios

## ACRYLICS

	1034575	50 ml	10	50 ml Mix Nozzle, Stepped Tip, 6.2" overall length, 6.5 mm inner diameter, 20 elements; 1:1, 2:1 mix ratios – B Cartridges.
	1573149	50 ml	10	50 ml Static Mix Nozzle, Stepped Tip; 6.18 inches long; 6.5 mm inner diameter; 20 elements; 1:1, 2:1 mix ratios.
	1084092	400 ml	10	490 ml Mix Nozzle, Stepped Tip; 11.2 inch overall length, 10 mm inner diameter; 24 elements, 10:1 mix ratio.
	1573135	400 ml	10	200/400 ml Mix Nozzle, Stepped Tip; 7.6 in. overall length, 6.3 mm inner diameter, 24 elements; 1:1, 2:1 mix ratio.
	1573138	400 ml	10	200/400 ml Mix Nozzle, Stepped Tip; 9.2 in. overall length, 8.0 mm inner diameter, 24 elements; 1:1, 2:1 mix ratio
	1084255	490 ml	10	490 ml Mix Nozzle, Stepped Tip; 9.1 in. overall length, 8 mm inner diameter, 24 elements; 10:1 mix ratio

## FLEXIBLE BONDING AND SEALING

## EPOXIES

	874905	400 ml	10	200/400 ml Square Mix Nozzle, Threaded Bell End, 114.5 mm inner dimension, 187 mm overall length, 24 elements; 1:1, 2:1 mix ratios.
	720174	400 ml	10	200/400 ml Round Mix Nozzle, Stepped Tip, 8.8 inch overall length, 8 mm inner diameter, 24 elements; 1:1, 2:1 mix ratios.

## LIGHT CURE TIPS

### 1/2" HIGH PRECISION STAINLESS STEEL DISPENSE TIPS - HELICAL THREAD

Product Image	IDH Number	Pacakge Qty.	Hub Color	Gauge
	600974	50	Amber	15
	900675	1000		
	567209	50	Green	18
	600976	1000		
	600977	50	Pink	20
	600978	1000		
	601003	50	Purple	21
	601007	1000		
	600979	50	Blue	22
	600982	1000		
	806854	50	Orange	23
	806855	1000		
	601000	50	Red	25
	601001	1000		
	569713	50	Lavender	30
	506201	1000		

### TAPERED DISPENSE TIPS - 1 1/4" POLYETHYLENE TAPERED TIPS, HELICAL THREAD & UV LIGHT BLOCK ADDITIVE

Product Image	IDH Number	Pacakge Qty.	Hub Color	Gauge
	600941	50	White	14
	600947	1000		
	600951	50	Grey	16
	600955	1000		
	600957	50	Green	18
	600958	1000		
	600959	50	Pink	20
	600971	1000		
	600972	50	Blue	22
	600973	1000		
	862838	50	Red	25
	862837	1000		
	862834	50	Clear	27
	862831	1000		

New LOCTITE<sup>®</sup> Pro Pump Handheld Dispenser for easy application.

For a full lineup of equipment to support your needs visit [equipment.loctite.com](http://equipment.loctite.com)



INDEX BY IDH NUMBER				
IDH No.	Product No.	Product Name	Package Size	Page No.
17544	4204™	LOCTITE 4204™ Instant Adhesive	20 g	44, 46
88448	277™	LOCTITE 277™ Threadlocker	50 ml	10, 12
88449	277™	LOCTITE 277™ Threadlocker	250 ml	10, 12
135266	SF 770™	LOCTITE SF 770™ Primer	1.75 oz.	45
135270	SI 5699™	LOCTITE SI 5699™ RTV Silicone	300 ml	27, 28
135275	SI 5699™	LOCTITE SI 5699™ RTV Silicone	70 ml	27, 28
135333	222MS™	LOCTITE 222MS™ Threadlocker	10 ml	9, 12
135334	222MS™	LOCTITE 222MS™ Threadlocker	50 ml	9, 12
135392	290™	LOCTITE 290™ Threadlocker	50 ml	9, 12
135393	290™	LOCTITE 290™ Threadlocker	250 ml	9, 12
135402	AA 326™	LOCTITE AA 326™ Adhesive	50 ml	63, 65
135412	AA 352™	LOCTITE AA 352™ Light Cure Adhesive	50 ml	91, 94
135413	AA 352™	LOCTITE AA 352™ Light Cure Adhesive	1 L	91, 94
135429	401™	LOCTITE 401™ Instant Adhesive	20 g	42, 43, 46
135430	401™	LOCTITE 401™ Instant Adhesive	1 lb	42, 43, 46
135433	403™	LOCTITE 403™ Instant Adhesive	20 g	44, 46
135436	406™	LOCTITE 406™ Instant Adhesive	20 g	44, 46
135462	454™	LOCTITE 454™ Instant Adhesive	20 g	42, 43, 46
135463	460™	LOCTITE 460™ Instant Adhesive	20 g	44, 46
135465	404™	LOCTITE 404™ Instant Adhesive	0.33 oz.	43, 46
135466	480™	LOCTITE 480™ Instant Adhesive	20 g	44, 46
135467	495™	LOCTITE 495™ Instant Adhesive	1 oz.	43, 46
135474	510™	LOCTITE 510™ Flange Sealant	50 ml	27, 28
135486	545™	LOCTITE 545™ Thread Sealant	50 ml	19, 20
135507	SI 596™	LOCTITE SI 596™ RTV Silicone	80 ml	27, 28
135512	609™	LOCTITE 609™ Retaining Compound	50 ml	35, 36
135513	609™	LOCTITE 609™ Retaining Compound	250 ml	35, 36
135514	620™	LOCTITE 620™ Retaining Compound	50 ml	35, 36
135515	620™	LOCTITE 620™ Retaining Compound	250 ml	35, 36
135527	660™	LOCTITE 660 Retaining Compound	50 ml	34, 36
135543	LB 771™	LOCTITE LB 771™ Nickel Anti-seize	1 lb.	116, 117, 118
135544	SF 790™	LOCTITE SF 790™ Parts Cleaner	18 oz.	28, 92
160796	LB 8008™	LOCTITE LB 8008™ Copper-based Anti-seize	1 lb	116, 117, 118
160809	SI 595™	LOCTITE SI 595™ RTV Silicone – Clear	80 ml	74
193996	SI 593™	LOCTITE SI 593™ RTV Silicone – Black	80 ml	74
193997	SI 593™	LOCTITE SI 593™ RTV Silicone – Black	300 ml	74
193999	SI 595™	LOCTITE SI 595™ RTV Silicone – Clear	300 ml	74
198817	SI 596™	LOCTITE SI 596™ RTV Silicone	300 ml	27, 28
199012	LB 8150™	LOCTITE LB 8150™ Silver Grade Anti-seize	8 oz.	117, 118
209676	PC 7317™	LOCTITE PC 7317™ Pneu–Wear	25 lb kit	97, 98
209681	EA 3463™	LOCTITE EA 3463™ Epoxy Repair Putty	4 oz..	105, 106
209715	SF 7649™	LOCTITE SF 7649™ Primer	4.5 oz.	11, 20, 28, 36
209758	LB 8009™	LOCTITE LB 8009™ Heavy Duty Anti-seize	18 oz.	117, 118
209816	PC 7319	LOCTITE PC 7319™ Chemical Resistant Coating	11 lb.	97, 98
209822	EA 3478™	LOCTITE EA 3478™ Superior Metal	1 lb. kit	105, 106
209824	PC 7317™	LOCTITE PC 7317™ Pneu–Wear	3 lb. kit	97, 98
209826	PC 7227™	LOCTITE PC 7227™ Brushable Ceramic	2 lb.	98
209827	PC 7222™	LOCTITE PC 7222™ Wear Resistant Putty	3 lb. kit	97, 98
219298	EA E-90FL™	LOCTITE EA E-90FL™ Adhesive	50 ml	62, 66
228171	O-Ring Making Kit	LOCTITE O-Ring Making Kit	Kit	124
229769	SF 7452™	LOCTITE SF 7452™ Accelerator	1.75 oz.	45
231121	641™	LOCTITE 641™ Retaining Compound	50 ml	35, 36

INDEX BY IDH NUMBER				
IDH No.	Product No.	Product Name	Package Size	Page No.
231232	SI 5910™	LOCTITE SI 5910™ RTV Silicone	300 ml	27, 28
231562	SF 7070™	LOCTITE SF 7070™ ODC-Free Cleaner	15 oz.	11, 20, 36, 45, 92
231944	4204™	LOCTITE 4204™ Instant Adhesive	1 lb.	44, 46
232743	AA 332™	LOCTITE AA 332™ Adhesive	300 ml	63, 65
232853	AA 392™	LOCTITE AA 392™ Adhesive	25 ml	63, 65
233317	LB 8008™	LOCTITE LB 8008™ Copper-based Anti-seize	1 lb.	117, 118
233675	403™	LOCTITE 403™ Instant Adhesive	1 lb.	44, 46
233962	EA E-00NS™	LOCTITE EA E-00NS™ Adhesive	50 ml	61, 66
234001	EA E-214HP™	LOCTITE EA E-214HP™ Adhesive	300 ml	62, 66
234020	460™	LOCTITE 460™ Instant Adhesive	1 lb.	44, 46
234048	480™	LOCTITE 480™ Instant Adhesive	1 lb.	44, 46
234138	AA 3494™	LOCTITE AA 3494™ Light Cure Adhesive	1 L	82, 84
234202	LB 8008™	LOCTITE LB 8008™ Copper-based Anti-seize	1 lb.	117, 118
234225	510™	LOCTITE 510™ Flange Sealant	250 ml	27, 29
234248	LB 771™	LOCTITE LB 771™ Nickel Anti-seize	1 lb.	116, 117, 118
234263	LB 8008™	LOCTITE LB 8008™ Copper-based Anti-seize	8 oz.	117, 118
234347	LB 8009™	LOCTITE LB 8009™ Heavy Duty Anti-seize	9 oz.	117, 118
234941	SF 7611™	LOCTITE SF 7611™ Parts Cleaner	19 oz.	91, 92
234981	SF 754™	LOCTITE SF 754™ Rust Treatment	1 qt.	124
235005	LB 8150™	LOCTITE LB 8150™ Silver Grade Anti-seize	1 lb.	111, 112
235018	SF 768™	LOCTITE SF 768™ Clean-up Solvent	1.75 oz.	45, 92
235028	LB 771™	LOCTITE LB 771™ Nickel Anti-seize	8 oz.	116, 117, 118
235573	PC 9410™	LOCTITE PC 9410™ Concrete Repair	5 gal.	123
235599	PC 9599™	LOCTITE PC 9599™ Fast Cure Wearing Compound	6 lb kit	97, 98
235637	PC 9626™	LOCTITE PC 9626™ Deep Pour Grout	5 gal.	123
237095	EA E-00CL™	LOCTITE EA E-00CL™ Adhesive	50 ml	61, 66
237099	EA E-05CL™	LOCTITE EA E-05CL™ Adhesive	50 ml	63, 66
237106	EA E-90FL™	LOCTITE EA E-90FL™ Adhesive	400 ml	62, 66
237107	EA E-20HP™	LOCTITE EA E-20HP™ Adhesive	50 ml	60, 66
237109	EA E-20HP™	LOCTITE EA E-20HP™ Adhesive	400 ml	60, 66
237110	EA E-60HP™	LOCTITE EA E-60HP™ Adhesive	50 ml	62, 66
237113	EA E-60NC™	LOCTITE EA E-60NC™ Adhesive	50 ml	63, 66
237115	EA E-60NC™	LOCTITE EA E-60NC™ Adhesive	400 ml	63, 66
237116	EA E-30CL™	LOCTITE EA E-30CL™ Adhesive	50 ml	63, 66
237118	EA E-30CL™	LOCTITE EA E-30CL™ Adhesive	400 ml	63, 66
237127	UK U-05FL™	LOCTITE UK U-05FL™ Adhesive	400 ml	63, 66
237128	EA E-120HP™	LOCTITE EA E-120HP™ Adhesive	50 ml	62,66
237130	EA E-120HP™	LOCTITE EA E-120HP™ Adhesive	400 ml	62,66
237295	406™	LOCTITE 406™ Instant Adhesive	1 lb	44, 47
261797	UK U-05FL™	LOCTITE UK U-05FL Adhesive	50 ml	63, 66
275026	LB 8023™	LOCTITE LB 8023™ Marine Grade Anti-seize	16 oz.	117, 118
299175	LB 8023™	LOCTITE LB 8023™ Marine Grade Anti-seize	8 oz.	117, 118
302892	Quick Service Tool Kit	LOCTITE Quick Service Tool Kit	Kit	124
312054	AA 3922™	LOCTITE AA 3922™ Adhesive	1 L	81, 84
312057	AA 3922™	LOCTITE AA 3922™ Adhesive	25 ml	81, 84
337637	SF 7617™	LOCTITE SF 7617™ WIPES	75 count	91, 92
411833	AA H8000™	LOCTITE AA H8000™ Adhesive	490 ml	62, 65
428557	PC 7393™	LOCTITE PC 7393™ Rapid Rubber Repair	400 ml	105, 106
457456	LB 8034™	LOCTITE LB 8034™ High Performance Synthetic Grease	3 oz.	112
462476	248™	LOCTITE 248™ Threadlocker Stick	19 g	9, 12

INDEX BY IDH NUMBER				
IDH No.	Product No.	Product Name	Package Size	Page No.
463973	561™	LOCTITE 561™ Thread Sealant Stick	19 g	19, 20
476035	MR 5426™	LOCTITE MR 5426™ Spray Adhesive	16.72 oz.	124
500995	LB 8008™	LOCTITE LB 8008™ Copper-based Anti-seize	1 lb	117, 118
544370	LB 8008™	LOCTITE LB 8008™ Copper-based Anti-seize	16 oz.	117, 118
544371	LB 8008™	LOCTITE LB 8008™ Copper-based Anti-seize	8 oz.	117, 118
555336	LB 8008™	LOCTITE LB 8008™ Copper-based Anti-seize	8 oz.	117, 118
618144	Toolbox	LOCTITE Toolbox	Toolbox	124
693986	SI 5031™	LOCTITE SI 5031™ Light Cure Adhesive	300 ml	82, 84
742348	SI 5039™	LOCTITE SI 5039™ Light Cure Adhesive	300 ml	82, 84
743912	SI 5900™	LOCTITE SI 5900™ Instant Gasket	90 ml	27, 28
743913	SI 5900™	LOCTITE SI 5900™ Instant Gasket	190 ml	27, 28
743914	SI 5900™	LOCTITE SI 5900™ Instant Gasket	190 ml	
826034	248™	LOCTITE 248™ Threadlocker Stick	9 g	9, 12
826035	268™	LOCTITE 268™ Threadlocker Stick	19 g	10, 12
826036	268™	LOCTITE 268™ Threadlocker Stick	9 g	10, 12
840057	435	LOCTITE 435™ Instant Adhesive	20 g	44, 46
840071	435™	LOCTITE 435™ Instant Adhesive	1 lb.	44, 46
1057673	AA 331™	LOCTITE AA 331™ Adhesive	25 ml	63, 65
1086598	EA E-05MR™	LOCTITE EA E-05MR™ Adhesive	50 ml	61, 66
1086599	EA E-05MR™	LOCTITE EA E-05MR™ Adhesive	400 ml	61, 66
1265769	5452™	LOCTITE 5452™ Thread Sealant	50 ml	19, 20
1265770	5452™	LOCTITE 5452™ Thread Sealant	250 ml	19, 20
1323940	PC 7218™	LOCTITE PC 7218™ Wearing Compound	25 lb. kit	97, 98
1324008	PC 7218™	LOCTITE PC 7218™ Wearing Compound	5 lb. kit	97, 98
1327836	PC 9313™	LOCTITE PC 9313™ High Impact Wearing Compound	25 lb. kit	97, 98
1329467	243™	LOCTITE 243™ Threadlocker	50 ml	8, 9, 12
1329505	243™	LOCTITE 243™ Threadlocker	250 ml	8, 9, 12
1330335	263™	LOCTITE 263™ Threadlocker	250 ml	8, 9, 12
1330585	263™	LOCTITE 263™ Threadlocker	50 ml	8, 9, 12
1401789	4311™	LOCTITE 4311™ Light Cure Adhesive	1 lb.	81, 84
1401790	4310™	LOCTITE 4310™ Light Cure Adhesive	1 lb.	81, 84
1401791	4311™	LOCTITE 4311™ Light Cure Adhesive	1 oz.	81, 84
1401792	4310™	LOCTITE 4310™ Light Cure Adhesive	1 oz.	81, 84
1511653	EA E-40EXP™	LOCTITE EA E-40EXP Adhesive	200 ml	63, 66
1537780	MR 5438™	LOCTITE MR 5438™ Threaded Plastic Pipe Sealant	16 oz.	19, 20
1540599	SI 5075™	LOCTITE SI 5075™ Insulating & Sealing Wrap	1" x 10'	123
1560557	MS 5510™	TEROSON MS 5510™ Elastic Sealant – Black	300 ml	74
1562040	MS 5510™	TEROSON MS 5510™ Elastic Sealant – Clear	300 ml	74
1562042	MS 5510™	TEROSON MS 5510™ Elastic Sealant – White	300 ml	74
1562044	MS 5510™	TEROSON MS 5510™ Elastic Sealant – Grey	300 ml	74
1616692	SF 7900™	LOCTITE 7900™ Ceramic Shield for Welding	9.5 oz	124
1677288	AA 3035™	LOCTITE AA 3035™ Adhesive	50 ml	63, 65
1690727	AA 330	LOCTITE AA 330™ Adhesive	25 ml kit	61, 65
1807961	3092	LOCTITE 3092™ Adhesive	10 g	44, 46
1835918	648™	LOCTITE 648™ Retaining Compound	250 ml	35, 36
1835920	648™	LOCTITE 648™ Retaining Compound	50 ml	35, 36
1835925	638™	LOCTITE 638™ Retaining Compound	250 ml	35, 36
1835936	638™	LOCTITE 638™ Retaining Compound	50 ml	35, 36
1875841	4902™	LOCTITE 4902™ Instant Adhesive	20 g	44, 46
1906177	LB 8421™	LOCTITE LB 8421™ Gear/Chain Lube	12 oz.	112
2012143	PC 7255™	LOCTITE PC 7255™ Sprayable Cereamic	900 ml	98
2046047	SF 7840™	LOCTITE SF 7840™ Cleaner & Degreaser	1 gal.	92

INDEX BY IDH NUMBER				
IDH No.	Product No.	Product Name	Package Size	Page No.
2046048	SF 7840™	LOCTITE SF 7840™ Cleaner & Degreaser	5 gal.	92
2060835	AA H8600™	LOCTITE AA H8600™ Adhesive	400 ml	63, 65
2061246	AA H4800™	LOCTITE AA H4800™ Adhesive	490 ml	62, 65
2068378	MS 939NA™	TEROSON MS 939NA™ Elastic Adhesive – Black	290 ml	72, 74
2069997	MS 939™	TEROSON MS 939™ Elastic Adhesive – White	290 ml	72, 74
2073202	PC 7350™	LOCTITE PC 7350™ Conveyor Belt Repair	400 ml	105, 106
2079209	PC 7210™	LOCTITE PC 7210™ Pipe Repair Epoxy	1 kg	123
2081197	MS 9399™	TEROSON MS 9399™ Elastic Adhesive	50 ml	73, 74
2081663	PC 5085™	LOCTITE PC 5085™ Glass Carbon Fiber Tape	30 m	123
2081666	MS 9399™	TEROSON MS 9399™ Elastic Adhesive	400 ml	73, 75
2082026	PC 7266™	LOCTITE PC 7266™ Sprayable Chemical Resistant Coating	1 kg	98
2087067	567™	LOCTITE 567™ Thread Sealant	50 ml	19, 20
2087069	567™	LOCTITE 567™ Thread Sealant	250 ml	19, 20
2096061	518™	LOCTITE 518™ Flange Sealant	300 ml	27, 28
2096064	518™	LOCTITE 518™ Flange Sealant	50 ml	27, 28
2123350	HY 4090™	LOCTITE HY 4090™ Universal Structural Adhesive	50 g	54
2137678	Powergrab	LOCTITE POWERGRAB Adhesive	300 ml	124
2138430	MS 930NA™	TEROSON MS 930NA™ Elastic Adhesive – White	290 ml	74
2138431	MS 930NA™	TEROSON MS 930NA™ Elastic Adhesive – Black	290 ml	74
2205827	HY 4090 GY	LOCTITE HY 4090 GY Universal Structural Adhesive	50 g	54
2244127	AA H8003™	LOCTITE AA H8003™ Adhesive	490 ml	62, 65
2248420	AA 3462™	LOCTITE AA 3462™ Light Cure Adhesive	1 L	82, 84
2264448	HY 4070™	LOCTITE HY 4070™ Universal Bonder	11 g	51
2298393	AA 3951™	LOCTITE AA 3951™ Adhesive	25 ml	81, 84
2298394	AA 3951™	LOCTITE AA 3951™ Adhesive	1 L	81, 84
2298717	AA 3953™	LOCTITE AA 3953™ Adhesive	25 ml	82, 84
2298718	AA 3953™	LOCTITE AA 3953™ Adhesive	1 L	82, 84
2343777	LB 8040™	LOCTITE LB 8040™ Fast Acting Corrosion Release	400 ml	112
2344218	SF 7625™	LOCTITE SF 7625™ Rust Converter	10.25 oz.	124
2374447	NS 5550™	LOCTITE NS 5550™ Extreme Temperature Sealant	1 quart	27, 28
2374452	NS 5540™	LOCTITE NS 5540™ Extreme Temperature Sealant	1 pint	27, 28
2392164	518™	LOCTITE 518™ Flange Sealant Pen	25 ml	26, 27, 28
2395759	PC 7383™	LOCTITE PC 7383™ Rubber Repair	10 kg kit	97, 98
2464890	AA 3961™	LOCTITE AA 3961™ Adhesive	25 ml	81, 84
2464891	AA 3961™	LOCTITE AA 3961™ Adhesive	1 L	81, 84
2483476	AA 3963™	LOCTITE AA 3963™ Adhesive	25 ml	81, 84
2483477	AA 3963™	LOCTITE AA 3963™ Adhesive	1 L	81, 84

***LOCTITE***<sup>®</sup>